

Operating manual / Information for use

Original operating manual



NORA Pro

Sit-to-stand lift

Version 0.2 / E

Subject to technical modifications

2022-09-13

WARNING



Before commissioning and using the medical device, the user / operator must familiarize himself with the scope of functions of the medical device by carefully reading this operating manual!



Table of contents

1	Imprint	4
1.1	Acknowledgement	4
1.2	Manufacturer's address	4
2	Introduction.....	5
2.1	Preface.....	5
2.2	Liability and warranty.....	5
3	Operating manual	6
3.1	Validity.....	6
3.2	Type plate	6
3.3	Description	6
3.4	Variants of the NORA Pro	6
4	Safety	7
4.1	Intended and appropriate use	7
4.2	Electrical safety	7
4.3	Follow / observe the operating instructions	8
4.4	List of used safety and warning signs.....	8
4.5	General warning and safety instructions	9
5	Transport and storage	13
5.1	Unpacking the product	13
5.1.1	Removing the cardboard.....	13
5.1.2	Loosening the product from the pallet.....	13
6	Installation	14
6.1	Electrical connection	14
6.2	First start-up	14
7	Operating elements and their function.....	15
7.1	Hand control.....	16
7.2	Functions and connections of the control unit	17
7.2.1	Control panel.....	17
7.2.2	Connections of the control unit.....	18
7.3	Battery unit	18
7.4	Charging the battery unit	19
7.5	Manual emergency lowering system	20
7.6	Emergency stop switch	21
7.7	Motor safety measures.....	22
7.8	Impact and jamming protection (hoist motor)	22
7.9	Spreader bar and sling attachment points.....	23
7.10	3D-Comfort-System.....	24
7.10.1	Detachable leg separator (option).....	24
7.11	Leg straps	25

7.12	Detachable footplate	26
7.13	Castors	27
8	Operation.....	28
8.1	Sling operating manual.....	28
8.1.1	Prior to use.....	28
8.1.2	During use.....	28
8.1.3	After use.....	29
8.2	Raising the patient from a chair or the bed (sitting position).....	30
8.3	Raising the patient from a wheelchair	32
8.4	Putting the patient/resident down	33
8.5	Operation of the sit-to-stand lift	34
8.6	Operation of the leg separator (option).....	35
8.7	Maintenance and care of the battery	35
9	Cleaning / disinfection	36
9.1	Cleaning the sit-to-stand lift.....	36
9.2	Disinfecting the sit-to-stand lift.....	36
9.3	Sterilising the sit-to-stand lift	36
10	Maintenance, safety checks and servicing.....	37
10.1	Prior to each use	38
11	Environmental protection / waste disposal.....	38
11.1	Disposal of the packaging material.....	38
11.2	Disposal of the product.....	38
12	Troubleshooting / After-sales service.....	39
13	Appendix.....	41
13.1	Technical description.....	41
13.2	Dimensions of the NORA Pro.....	43
13.3	Connection and assembly diagram	44
13.4	Declaration of Conformity	45
13.5	Additional equipment, accessories, and spare parts	49
13.6	Mounting instructions	51
13.6.1	Replacing the battery	51
13.6.2	Replacing the hand control	52
13.6.3	Replacing the control unit with holder for the battery unit	53
13.7	Electromagnetic compatibility	54
13.8	Journal	58

1 Imprint

1.1 Acknowledgement

Dear customer, we would like to express our sincere thanks for the trust you have placed in us by purchasing this BEKA Hospitec GmbH product. Our products are manufactured and tested according to stringent quality criteria.

1.2 Manufacturer's address

We will be happy to advise you on questions about our products and to help you with any problems. For this purpose, please contact:

	<p>BEKA Hospitec GmbH Am Rübenmorgen 3 35582 Wetzlar Phone: +49(0)641-9 22 20-0 Fax: +49(0)641-9 22 20-20 info@beka-hospitec.de</p>
---	--

	<p>BEKA Hospitec GmbH is certified according to DIN EN ISO 13485 by TÜV SÜD Product Service GmbH. Therefore, the development, manufacturing, quality assurance and service of our entire product range is subject to high quality standards.</p>
---	--

<p>ATTENTION</p> 	<p>Before each use, check that all visible parts are undamaged. If parts are damaged, the product must NOT be used!</p> <p>Before each use of the device and its accessories, the user must make sure that they are safe to operate and in proper condition (visual inspection, function).</p>
---	--

2 Introduction

2.1 Preface

A correct use of the device is imperatively in order to ensure its proper and safe functioning. Please read the provided operating manual carefully and observe in particular the therein contained safety instructions.

The maintenance, inspection, assembly and installation as well as well as further technical interventions on the product must only be executed by BEKA Hospitec or by specialised companies authorised to this effect by BEKA Hospitec. The operation of the product as well as technical interventions on the product must only be carried out by specially trained personnel.

The NORA Pro is a medical device according to DIN EN 60601-1 / IEC 60601-1 and DIN EN 60601-1-2 / IEC 60601-1-2 as well as MDR Medical Device Regulation (EU) 2017/745. The product is used for raising and transferring patients and care-dependent persons.

If a serious incident should occur in connection with the use of the product or its accessories involving a patient or user, contact your distributor or the manufacturer. In the European Union, you are obliged to report serious incidents to the competent authority of the respective member state. Other regulations may apply in other regions.

2.2 Liability and warranty

- On the basis of the information contained in this manual, the publisher accepts no liability for damages resulting from improper, incorrect or inappropriate use of the product. The product must only be operated by persons, who are familiar with the manual and the product as well as the national regulations, laws and prescriptions related to work, safety and accident prevention.
- The manufacturer of the product is only responsible for the safety and the reliability of the product, if regular functional tests and checks are conducted. Operate the product only with original accessories, otherwise the manufacturer's liability will expire.
- In case of technical interventions, such as extensions and fittings to our products, which are not carried out by BEKA Hospitec either by a specialist company authorised by BEKA Hospitec, all warranty rights on the modifications as well as on the device or on the device function, which are related to the modification, shall expire.
- For damages resulting from the use of spare parts and accessories, which are not authorized by the manufacturer, any further liability of the manufacturer shall be excluded.
- Please note that there might be minor differences between the images and explanations contained in this manual and the actually supplied device. Subject to technical modifications and error.
- The product is equipped with "B"-Type applied parts. All exposed, touchable, conductive parts are thereby considered as applied part.

3 Operating manual

3.1 Validity

This operating manual contains information, which is required for the operation and use of the product. In addition to the description of the equipment, the operating manual also includes a number of abstractions and exemplary illustrations. The equipment of the product therefore may differ in part from the descriptions and illustrations. Furthermore, please observe also the manuals with regard to the cleaning and the disinfection as well as the assembly and the disassembly of individual components of the product.

Please read the operating manual and the safety instructions before starting to use the product. Keep the operating manual near the device for future reference.

3.2 Type plate

		<p>This image shows the type plate. The type plate is located at the column support of the NORA Pro.</p> <p>The shown serial number (SN) is just an example. In case of queries, please mention the serial number printed on the type plate of your device.</p> <p>Note: Because of legal regulations, it might be required that the article number and the serial number should be computer-readable as well and therefore they might be printed on the type plate in the form of a bar code as well.</p>
--	--	--

3.3 Description

In this manual, the product is called NORA, NORA Pro, sit-to-stand lift, or device. These names always refer to the same product.

3.4 Variants of the NORA Pro

Sit-to-stand lift	Description	Note
NORA Pro, model BAROLO Incl. external charger	Colour design „BAROLO“ RAL 3007	921077000
NORA Pro, model RUBIN Incl. external charger	Colour design „RUBIN“ RAL 3004 Especially suitable for people with dementia	921078000

4 Safety

4.1 Intended and appropriate use

The product was specially developed for use in medical technology. It has been designed for raising and transferring patients and residents. The patient is raised from a sitting position. The NORA Pro is to be used exclusively for the indoor transfer of residents on level floorings. The NORA Pro is designed for short-term use and any contact with injured skin must be avoided.

The sit-to-stand lift is suitable for patients with a body height of 1.48 m to 1.97 m (4'10" to 6'6") and a maximum body weight of 205 kg (451 lbs).

Please note that the product is not protected against the effects of greater mechanical forces and only to a limited extent against the penetration of splash water into the housing, motor, control unit and battery. The product is not intended for operation in atmospheres with flammable mixtures!

The product may only be used for the specified purpose. Also observe the general warning and safety instructions in section 4.5.

CAUTION



Before the product is used, adequately qualified staff must assess the physical and mental condition of the patient/resident. In order to facilitate this, corresponding assessments/routines must and should be used in the daily care processes.

CAUTION



The patient/resident must have sufficient core stability (capability of sitting autonomously on the edge of the bed is an indicator for a sufficient core stability).























4.2 Electrical safety

The product meets the current VDE-prescriptions 0100 for installing low-voltage systems and 0100-710 on requirements for special types of operating sites, rooms and systems - medical areas. However, have a specialist company check the compliance of your electrical installation with the applicable prescriptions prior to operating and using the product. This requirement is only applicable for Germany. In other countries, other requirements might be applicable. Ask a qualified electrician to proceed with the installation in accordance with the regulations applicable in your country.

4.3 Follow / observe the operating instructions

Please read the following safety instructions prior to using the product. All notes, specifications and warnings mentioned on the device as well as in the present operating manual must be imperatively respected and observed. The manufacturer BEKA Hospitec shall *not* accept any liability for any damages, failures or faults caused by improper operation or handling.

4.4 List of used safety and warning signs

	Follow the operating instructions / observe the instructions.		General Recycling Symbol.
	Medical device.		Air pressure limits (minimum air pressure / maximum air pressure).
	CE-label in accordance with MDR.		Humidity limits (minimum humidity / maximum humidity).
	Name and address of the manufacturer.		Temperature limits (minimum temperature / maximum temperature).
	Date of production.		Do not push/pull the motor. Do not push/pull the spreader bar.
	Warning hazardous area.		Washing temperature max. 60 °C. Normal cycle.
	Caution.		Do not bleach.
IPX4	Protection against harmful ingress of water or solid substances: Protected against splashing water.		Line dry.
	Applied part "Type B" in accordance with DIN EN 60601-1.		Do not tumble dry.
	Protection class II.		Do not iron.
	Solely intended for indoor use.		Professional wet cleaning. Gentle cycle.
	Must not be disposed of with household waste. Do not put the treatment system and packaging materials in the household waste.		

4.5 General warning and safety instructions



General notes

- The product may only be used for the purpose specified in chapter 4.1 Intended and appropriate use.
- The product may only be installed, maintained, and put into operation by persons authorised by the manufacturer who meet the requirements according to §2 Para. 2 the MPBetreibV (German Medical Devices Operator Ordinance). Observe your applicable national / local legislation on operating medical devices.
- The company reserves the right to make modifications to the device without prior notice.
- When using the device, observe all regulations of the German Medical Devices Implementation Act (MPDG) and all related ordinances as well as the occupational health and safety regulations, the accident prevention regulations (UVV) and the generally recognised rules of technology. For use outside Germany, observe the respective national legislation.
- This product is a medical device according to Medical Device Regulation (EU) 2017/745 (MDR) and DIN EN 60601-1. For operators in Germany, the MPBetreibV (German Medical Devices Operator Ordinance) is binding. In other countries, the corresponding national laws apply. The insulation distances present in the product meet the requirements of the standard: DIN EN 60601-1 (IEC 60601-1) Medical electrical equipment, Part 1: General requirements for safety.

Operating Environment

- The product is exclusively fit for indoor use.
- The product is not protected against the effects of greater mechanical forces and only to a limited extent against the penetration of splash water into the housing, motor, control unit and battery.
- The device is not authorised for use in potentially explosive atmospheres or in atmospheres with flammable mixtures or increased oxygen content.
- Electromagnetic or other interference between the product and other devices cannot be ruled out. If there is a risk of alternating influences, disconnect the product / battery charger from the mains. The use of short-wave or microwave therapy devices in the immediate vicinity of the device is strictly forbidden. Cellular phones can also cause interference.
- Protect the product against direct sunlight and heat.

Functional safety

- The product as well as the slings may only be used and operated by trained staff.
- Supervision of the caregiver is required throughout the treatment. Never leave the resident unattended in the sling.
- The patient must not be the user / operator!
- Prior to each use of the device and its accessories, the user must check their functional safety and good condition (visual check, functioning). Also check the used sling for visible damage. The product and the accessories must not be used if any parts are damaged or malfunctioning. There is a risk of injury!
- Only operate this medical device with original accessories according to chapter 13.5.
- Make sure that the sling form and size match the patient's body. Respect and observe the size and weight specifications for each sling.

- In case of differences in the maximum load for the sit-to-stand lift and sling system, always observe the lowest maximum load.
- Each lifting or transfer procedure must be adequately planned to ensure an optimal protection for the caregiver and the resident.
- Lift the patient/resident into a safe standing position and keep the transfer as short as possible.
- Avoid slippery surfaces and thresholds and do not move the product over sloping or uneven floors.
- Make sure that the resident is not hurt by the door frame when passing through doors.
- Activate the brakes of the castors of the wheelchair, the healthcare bed, the stretcher, etc. to ensure a safe lifting and positioning of the resident.
- Check prior to lifting that all clips or loops are correctly fixed to the spreader bar.
- Make sure that the patient seizes the handles provided to that effect with both hands.
- Make sure that no one grabs in the hazardous areas (bracket, carrier frame) during the adjustment procedure. Only use the adjustment of the carrier frame when there is nothing in its range of movement. Pay particular attention to your feet and those of the patient. Risk of crushing!
- Please check before and during the height adjustment procedure that your feet are not located in the area of the castors or in the resident's area.
- The operating time and the maximum load of the lifting unit must not be exceeded (see 13.1 Technical description).
- During the movement of the sit-to-stand lift, the carrier frame must be closed.
- Do not stand between the sit-to-stand lift and an obstacle during the transfer procedure.
- Ensure that the power supply is always switched on throughout the usage.
- Hazardous substances are enclosed in the battery. To avoid the risk of fire and explosion as well as leakage of these substances, do not open the batteries or handle them mechanically in any way! Never expose the batteries to open fire, excessive heat (e.g. over heaters) or solar radiation!
- Do not use the product when the battery is charging.
- Make sure that the battery is charged in a well-ventilated room.
- Route the mains connecting cable of the charger so that it cannot be damaged. Damaged mains cables could cause fire or lead to electrocution and must not be used.
- Never cover up, over sticker or change the slots and holes of the device.
- The housing of the product must not be opened! There are no user-serviceable parts inside the product. Never insert foreign objects into the product.
- Do not carry out any repairs or modifications to the product! Otherwise, the correct functioning of the product and safety may be jeopardized. This will also void your warranty claims! Repairs may only be carried out by trained specialist personnel authorised by the manufacturer. Be sure to contact BEKA Hospitec's customer service or that of its authorised distributors.
- The product must be disinfected after each treatment.
- Cleaning and disinfection are only allowed without patient presence!
- The caregivers must protect their skin and eyes against concentrated disinfecting and cleaning products. Use a face mask to protect yourself against aerosols.

Maintenance

- To ensure a safe use of our product, the product must be subjected annual inspections, safety check and maintenance by persons authorised by the manufacturer who fulfil the requirements according to MPBetreibV (German Medical Devices Operator Ordinance). Outside Germany, observe the local laws and regulations. For more details, see chapter 10. If in doubt, contact your supplier or manufacturer. Non-observance may result in injuries or an unsafe product.
- Installation, maintenance, servicing and testing activities are only permitted without the patient being present!
- The product contains detachable parts. Observe chapter 7 for correct identification of the parts to avoid the risk of confusion and malfunction.
- The product contains non-removable parts. If necessary, these may only be replaced by personnel authorised by the manufacturer. Observe the assembly instructions in chapter 13.6.

Environmental protection / waste disposal

- The manufacturer is aware of its responsibility towards the environment. The product must not be disposed of with household waste!
- In accordance with WEEE, the manufacturer takes back all equipment placed on the market by him for the purpose of proper disposal. Please contact us in this regard if necessary and inform your customers in the case of resale.

Notes for operation

- When used together with other medical devices, watch out for catching points and pinching as well as crushing of the patient's body or parts of the patient's body! Also watch out for instability / tipping during transfer of the patient!

CAUTION



In case of unusual noises, damages or malfunctions, the product no longer must be used.

CAUTION



Repairs to components of the product are to be carried out only by trained expert personnel, authorized by the manufacturer. Please contact the after-sales service.

The opening the device or other accessories will lead to the expiration of all guarantee, warranty and liability claims.

WARNING



Any unauthorized repairs, reconstructions and modifications/alterations are not permitted for safety reasons and shall exclude all liability of the manufacturer for the resulting damages.

For damages resulting from the use of spare parts or accessories, which are not authorized by the manufacturer, any further liability of the manufacturer shall be excluded.

CAUTION



Do not leave the patient/resident unattended at any time, to avoid injuries, falls or similar.

CAUTION



This device could contain small parts, which could be inhaled or swallowed, thus representing a choking/suffocation hazard to small children. Keep children and domestic animals away from the device.

The hand control represents a strangulation hazard. Take all precautions to avoid this.

5 Transport and storage

For safe transport, storage and operation, observe the permissible ambient conditions in chap. 13.1 Technical description.

Use a lift truck or similar for the transport.

5.1 Unpacking the product

To remove the packaging materials, you will need a cutter knife.

NOTE



Take care not to damage the product when using tools.
Do not cut with the cutter in the cardboard.

5.1.1 Removing the cardboard

Proceed in the following way to remove the cardboard:

- Cut the strap with the cutter knife.
- Remove the strap.
- Lift the cardboard up to remove it and put it aside.

5.1.2 Loosening the product from the pallet

Both sides of the product are strapped to the pallet.

Proceed in the following way to loosen the product from the pallet:

- Unscrew the fixing screws of the straps.
- Remove the straps and the cardboard underlays (if present).
- Please make sure that the brakes of the castors are released.
- After all fixations have been released, the product can be driven off the pallet.
- Remove the bubble wrap and the stretch film.

The accessories of your product are included in the supplied cardboard box.

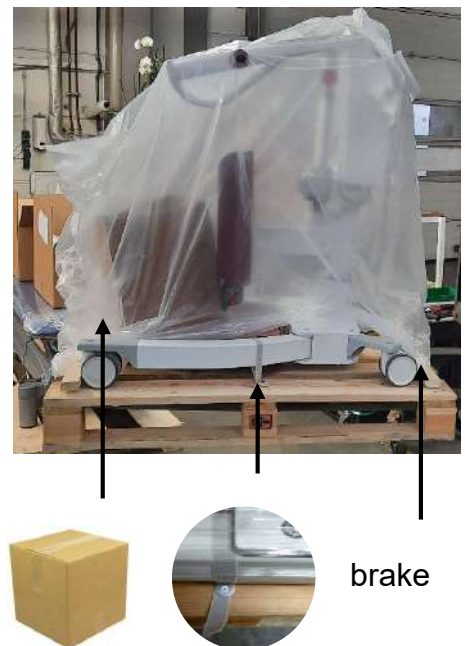

6 Installation

The product is supplied ready for use.

6.1 Electrical connection

Before you start using our products, your electrical installation must be checked in accordance with the relevant VDE-regulations 0100 and 0100-710. This requirement is only applicable in Germany. In other countries, other requirements might be applicable.

Ask a qualified electrician to install the charging unit in accordance with the regulations applicable in your country. The socket must meet the requirements of VDE 0100 and 0100-710.

6.2 First start-up

WARNING



The equipment is to be used exclusively in accordance with the accompanying documents.

Only when these conditions are met, the manufacturer considers himself responsible for the impact on the safety, the reliability and the function of the device.

In the event of a newly connected product, the technical data must be observed.

HINWEIS



The battery must be completely charged prior to the first use (initial charging time min. 12 hours).

Please check that the emergency stop switch is released prior to moving the spreader bar.

The NORA Pro sit-to-stand lift is equipped with an electrical motor. This motor is self-locking and therefore protected against unintentional lowering of the spreader bar in case of malfunction or failure. The battery of the NORA must be completely charged before starting to use the device.

Please check that the emergency stop switch is released (unlatched). To unlatch, turn the button of the emergency stop switch clockwise (i.e., to the right) until it releases.



7 Operating elements and their function

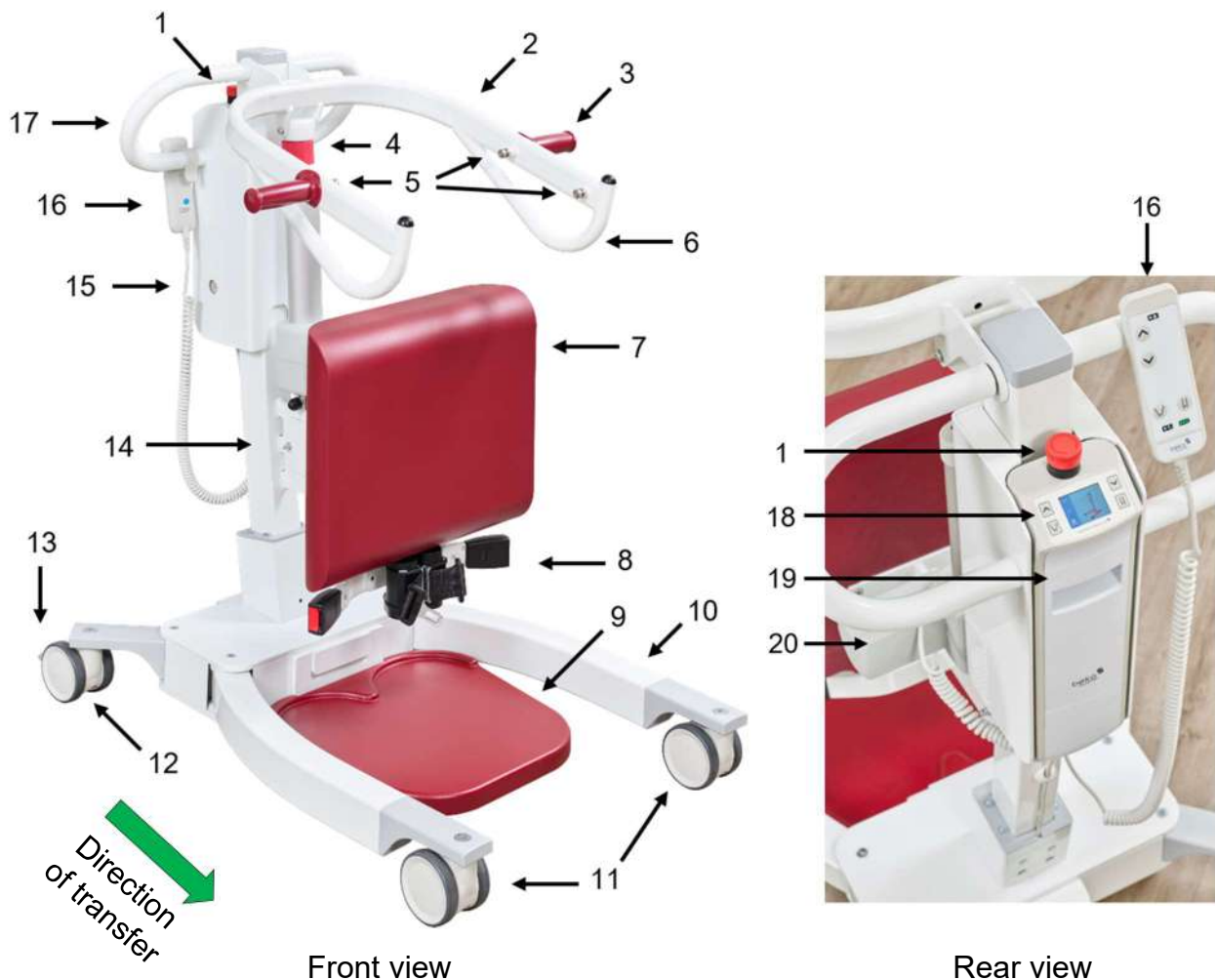

N°	Description	N°	Description
1	Emergency stop switch	11	Front castors
2	Spreader bar	12	Rear castors
3	Handles (patient / resident)	13	Parking brake
4	Emergency lowering system	14	Tilting mechanism of the 3D-Comfort-System
5	Sling attachment points	15	Charger cable connection
6	Additional handles (patient / resident)	16	Hand control
7	3D-Comfort-System (Leg pad)	17	Positioning handle (user)
8	Safety belts for the legs	18	Control panel
9	Detachable footplate	19	Battery
10	Spreadable carrier frame	20	Motor







The contact surfaces of the NORA Pro are designed in a dementia-sensitive red colour scheme. In addition to the model RUBIN shown here, the dark red coloured model BAROLO is also available.

7.1 Hand control







With the hand control, you can move the spreader bar up or down and spread or close the carrier frame. Pressing the buttons activates the function; as soon as you release the button, the function stops.



Functions

-  "Up" button
-  "Down" button
-  Spreading the carrier frame
-  Closing the carrier frame
-  Service required
-  Max. weight reached
-  Battery charge status

The LED indicators provide information about the battery status and indicate when maintenance is due or when the safe working load has been exceeded.

-  3 bars: Battery is full, no charging required (remaining capacity >75%).
-  2 bars: Battery is at least half full and can be charged (remaining capacity >55%).
-  1 bar: Battery is almost empty and must be charged (remaining capacity >25%).
-  No bar: Battery is almost empty and must be charged urgently (remaining capacity <25%)! In addition, a signal tone sounds when the button is pressed.
-  LED flashes orange. Please have your sit-to-stand lift checked!
-  Orange LED, overload, max. weight of 205 kg exceeded.

7.2 Functions and connections of the control unit







7.2.1 Control panel

With the control panel you can move the lift arm up or down, as well as spread or close the carrier frame. Pressing the buttons activates the function; as soon as you release the button, the function stops.







The display shows a dynamic animation of the activated movement. On the left side of the display are counters that record cycles of the up and down movement and the exceeding of the maximum load. One minute of motor activation is counted as one cycle. If no button is pressed for more than 2 minutes, the NORA Pro display switches off to save energy. As soon as you press any button, the NORA Pro is activated again.



Functions

-  "Up" button
-  "Down" button
-  Spreading the carrier frame
-  Closing the carrier frame
-  Max. weight reached
-  Battery charge status
-  Counters for lifting / lowering operations

The control panel also provides information about the operating status of your NORA Pro. The charge level and, if applicable, overload can be read as described below.

-  3 bars: Battery is full, no charging required (remaining capacity >75%).
-  2 bars: Battery is at least half full and can be charged (remaining capacity >55%).
-  1 bar: Battery is almost empty and must be charged (remaining capacity >25%).
-  No bar: Battery is almost empty and must be charged urgently (remaining capacity <25%)!
-  In addition, the adjacent warning symbol appears in the display and a signal sounds when a button is pressed.
-  The weight symbol appears in the display. Overload: The max. weight of 205 kg has been exceeded.
-  The symbol for internal charging appears in the display. The battery is being charged inside the NORA Pro.

7.2.2 Connections of the control unit

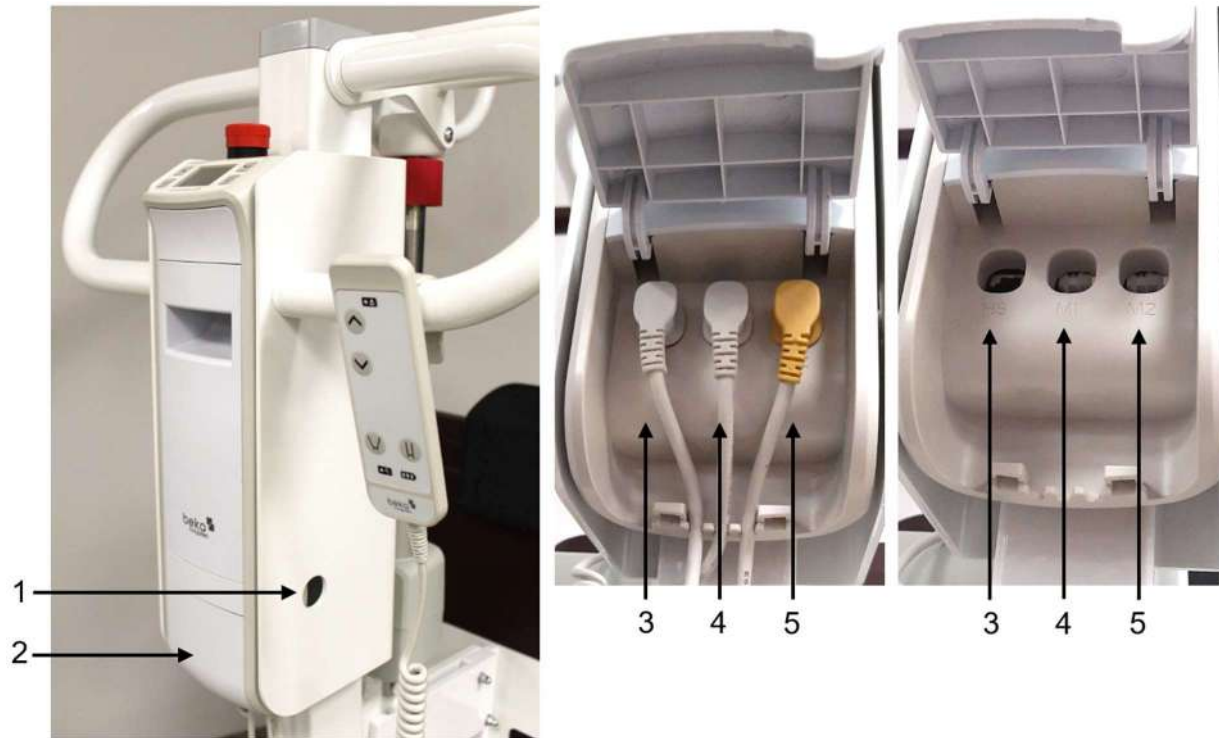

N°	Description	N°	Description
1	Charger cable connection	3	Hand control connection "HS"
2	Flap for concealed connections (to open, see chap. 13.6)	4	Lifting motor connection "M1"
		5	Spreading motor connection "M2"

7.3 Battery unit

The NORA sit-to-stand lift is equipped with a 25V battery. Proceed as described in chapter 13.6.1 to remove the battery.

WARNING



Hazardous substances are contained in the batteries. Do not open the batteries or manipulate them in any way!

If the contents of the battery should come into contact with skin or clothing, wash the affected areas with plenty of water as soon as possible.

If any of the ingredients of the battery get into your eyes, rinse them immediately with plenty of water and then consult a doctor.

Vapours of the ingredients may cause respiratory irritation. Bring affected persons into fresh air and then seek medical advice.



WARNING



Never expose the battery to open fire or excessive heat! There is a risk of fire and explosion!

7.4 Charging the battery unit

CAUTION



Do not use the product when the battery is charging.
Make sure that the battery is charged in a well-ventilated room.

CAUTION



Route the mains connecting cable of the charger so that it cannot be damaged. Damaged mains cables could cause fire or lead to electrocution and must not be used.

The external charging station can either be placed on a flat surface or attached to a suitable wall using the included mounting rail. The required power supply unit is a switched-mode power supply charger and is included in the scope of delivery.

As soon as the charging station is supplied with voltage, the charging indicator LED lights up green. If a battery is plugged in and charged, the colour changes to orange. When the battery is fully charged, the colour changes back to green.

The charging time for the battery units is approx. 5 hours.

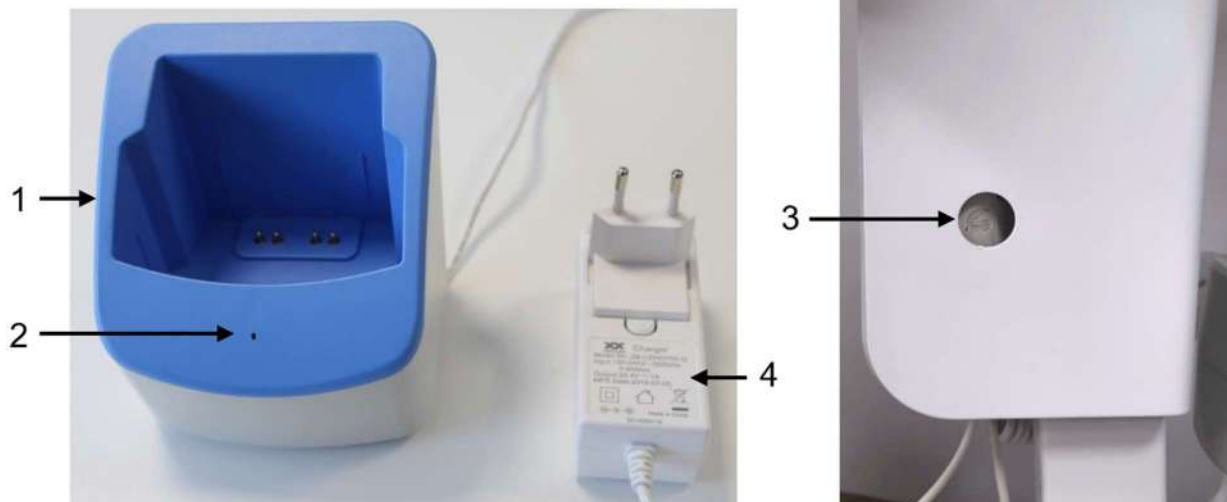

Nr.	Beschreibung	Nr.	Beschreibung
1	Charging station with battery mount	3	Charger cable connection
2	Charging indicator	4	Power supply unit

Alternatively, the plug of the power supply unit can be disconnected from the charging station and used directly for internal charging of the Nora Pro. To do this, use the connector on the side of the NORA pro control unit. Remove the rubber plug that closes the socket of the charging plug and insert the plug of the delivered power supply unit. For internal charging, make sure that the emergency stop switch is unlocked.

7.5 Manual emergency lowering system

Ensure that the patient / resident can be lowered onto a suitable surface such as a chair or bed.

Turn the bright red emergency lowering knob clockwise until the spreader bar slowly lowers, thereby lowering the patient / resident onto the selected surface.

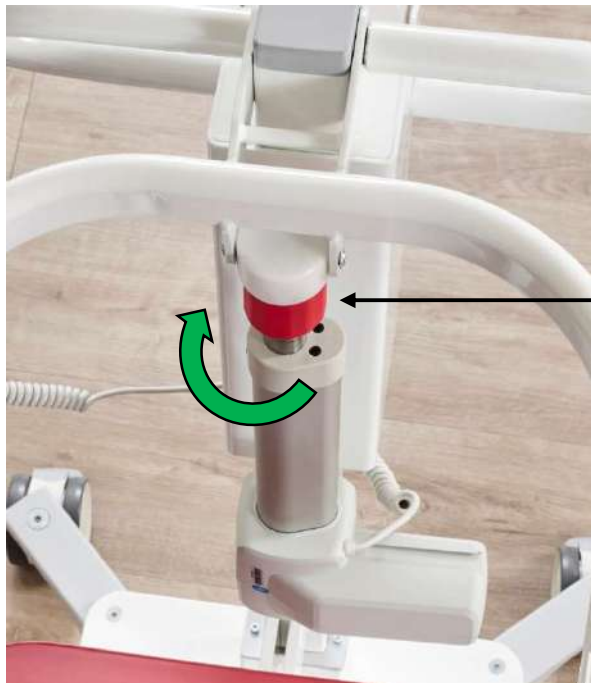

manual emergency
lowering system

7.6 Emergency stop switch

Locking

Press the emergency stop button to activate it. When the emergency stop switch is pressed, the electric motors are immediately disconnected from the power supply. The motor stops immediately. The motor is self-locking and thus prevents the lift arm from dropping in the event of a fault.

The emergency stop switch should be used immediately if there is immediate danger to the patient or the operating personnel!

However, it can also be used to reduce discharging of the battery during intermediate storage. In addition, you can lock the NORA sit-to-stand lift by pressing the emergency stop switch and thus make unauthorised use more difficult.

Unlocking

Before use, check whether the emergency stop switch is unlocked. To unlock, turn the knob clockwise until it is unlocked (the knob lifts).

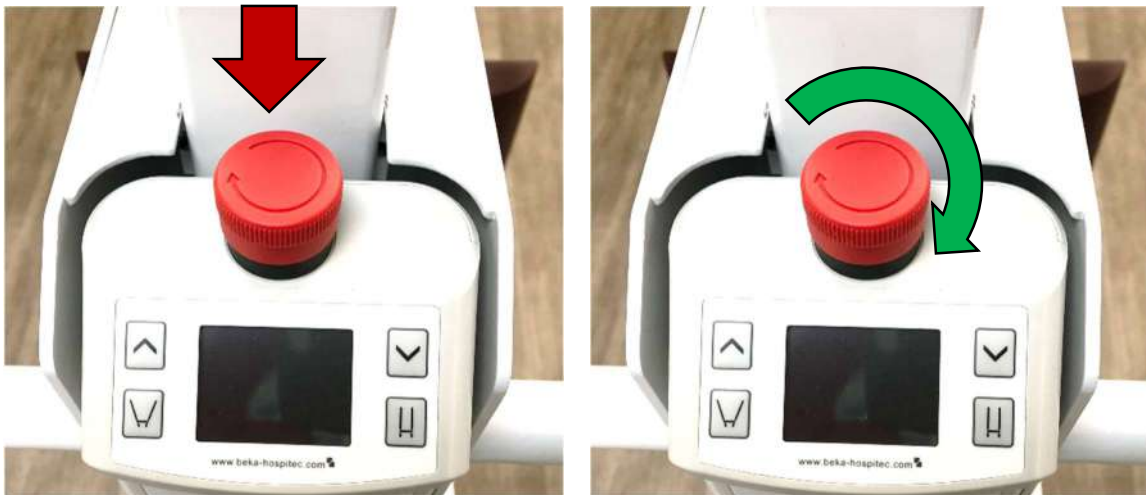

Activating the emergency stop switch Deactivating the emergency stop switch

NOTE



The battery can only be charged internally when the emergency stop switch is not actuated!

7.7 Motor safety measures

The control of the electrical motor is equipped with an overload protection, which is autonomously switched off in case of overload. The motor will only be operational again after a short waiting time. The cooling-off time of the motor can be up to 18 minutes depending on the ambient temperature.

HINWEIS



The intermittent operation of the motor is not a defect but is only for your own safety. Opening the motor will result in expiration of the warranty!

7.8 Impact and jamming protection (hoist motor)

The electrical motor (hoist motor) features an integrated impact and jamming protection (free wheeling). This feature avoids jamming, pinching and/or crushing dangers when the spreader bar of the NORA sit-to-stand lift strikes or encounters an obstacle. The motor runs free until the obstacle is removed or the NORA sit-to-stand lift is removed from the obstacle.

After the obstacle has been removed, the spreader bar could start lowering autonomously. Therefore, you must immediately release the button of the hand control as soon as you have noticed that an obstacle has been encountered. Press the "Up" button until the lifting arm is again freely above the obstacle. Only then may the sit-to-stand lift be pulled away from the obstacle.

7.9 Spreader bar and sling attachment points

There is a total of four attachment points for the NORA Pro clip sling on the spreader bar. The outer, opposing attachment points are the default attachment points for people taller than 1.60 m. The two inner attachment points are optimally adapted for people with a body height of less than 1.60 m.



 Default sling attachment point
Attach sling with sling clip 1

 Optional sling attachment point
for patients and residents
shorter than 1.60 m



WARNING



Observe the instructions for use of the sling! Always make sure that the fastening clips are secured and in the correct position before lifting your patient/resident!

7.10 3D-Comfort-System

The patented 3D-Comfort-System (leg padding) is particularly flexible and comfortable. The material made of multi-layer memory foam adapts ergonomically to the shape of the leg. The counterpressure of the knees forms precisely fitting hollows that provide comfortable and secure support when standing up.

The additional tilting mechanism also improves the even sinking in of the leg for patients / residents with different body heights.



7.10.1 Detachable leg separator (option)

The leg separator made of skin-friendly PE material is placed on the 3D-Comfort-System from above and can just as easily be removed again by pulling it upwards slightly (double arrow).



7.11 Leg straps

There are two safety straps underneath the 3D-Comfort-System. These serve to secure one leg of the patient / resident at a time against slipping.

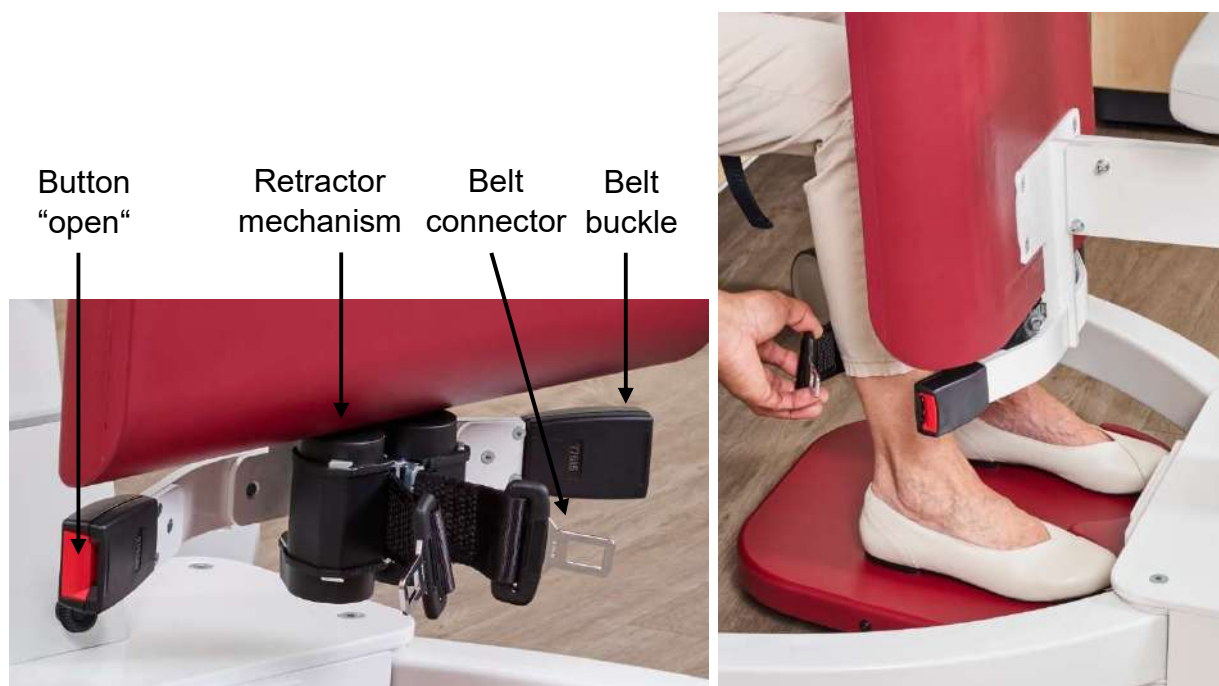

Closing the leg strap

To put on the safety strap, ask the patient/resident to position his/her knees and shins so that they touch the 3D-Comfort-System. Now pull a leg strap from the retractor from behind and place it around the patient's/resident's calf.

Click the Belt connector audibly into the belt buckle to close it. Due to the retractor mechanism, the leg strap automatically tightens and adjusts to the patient's/occupant's legs.

Repeat this procedure with the other leg.

During the raising process, keep the leg safety belts closed.

Opening the leg strap

To open the leg strap, press the red button on the buckle. The connector is released and the strap is automatically retracted by the retractor mechanism.

7.12 Detachable footplate

The foot plate enables the patient / resident to stand securely. It can be easily detached from the NORA Pro for cleaning.



Remove the foot plate

Take the footplate in both hands. Lift the footplate slightly upwards so that it releases from the suspension at the back.

Now remove the footplate by pulling it forward.

Hanging up the footplate

Take the footplate in both hands. Put the metal opening at the back of the footplate back into the mounting.

Now lower the footplate and let it snap into place. Make sure that the footplate is again in a horizontal position.

7.13 Castors

The rear castors of the NORA Pro have brakes and can be locked.

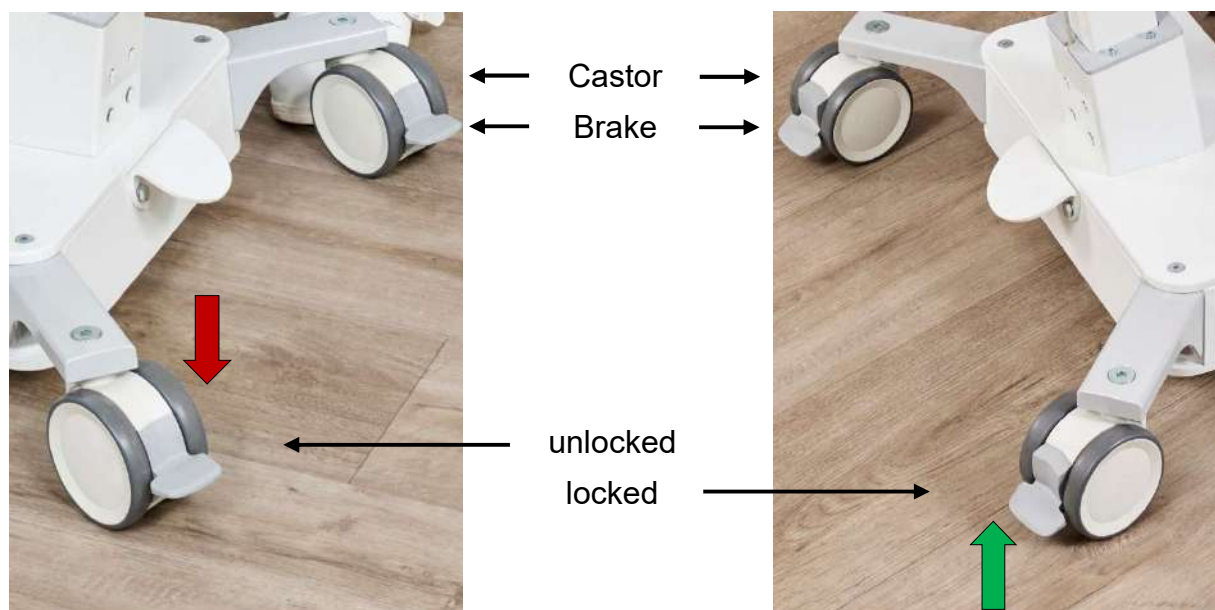

Locking the brake

Press the light grey castor brake down with your foot (illustration left, red arrow).

Releasing the brake

Press the light grey castor brake upwards with your foot (illustration on the right, green arrow).

8 Operation

The NORA Pro is designed to be safely operated by a single caregiver. Before each use, it is the responsibility of the caregiver to decide, based on the assessments, whether the transfer should be made by one person alone or by two caregivers.

Please do not hesitate to seek advice from your healthcare professional if in doubt.

8.1 Sling operating manual

Important note:

The service life of BEKA belts is a maximum of 36 months from the first use. The specified service life is only applicable, when the BEKA-slings are cleaned, maintained and inspected in accordance with the instructions contained in the following documentation.

8.1.1 Prior to use

The slings must be checked before and after each use and, if necessary, be washed in accordance with the manual. This is prescribed in particular to reduce the risk of infections to an absolute minimum, in the event that the same equipment is used for other residents or patients.

<p>CAUTION</p> 	<p>Prior to each use, a thorough check of the sling including the loops and the fastening clips is imperatively required. If the sling or the loops would be frayed, cut-in or damaged, or the clips would be damaged, the sling no longer must be used.</p>
---	--

<p>CAUTION</p> 	<p>Make sure that the sling form and size match the patient's body. Respect and observe the size and weight specifications for each sling.</p> <p>In case of differences in the maximum load for the sit-to-stand lift and sling system, always observe the lowest maximum load.</p>
---	--

Please make sure that a sling of the correct size is used for the resident.

Prior to lifting the patient or the resident, the situation must be assessed by a qualified employee or a therapist. This also applies to care-dependent persons with limited or reduced shoulder mobility or for patients who are unable to hold themselves with one or both hands.

8.1.2 During use

<p>WARNING</p> 	<p>The use of incompatible (i.e. non-BEKA Hospitec) slings can cause accidents!</p>
---	---

Check that the sling attachment points at the sit-to-stand lift match the sling clips.

Check that the sling is not twisted when attaching the sling. Always check that the sling clips are correctly attached prior to and during the lifting procedure and that they are tensioned while supporting the patient's weight.

Please take extreme care when using the sling and encourage the patient to hold on tight to the handles of the spreader bar.

8.1.2.1 Safely attaching the clips to the support

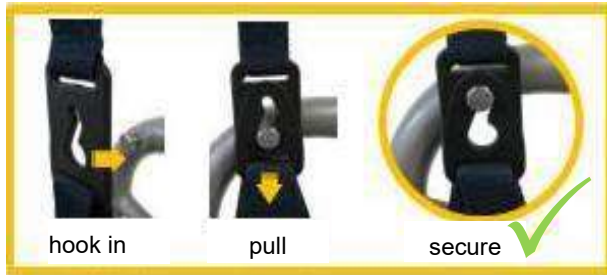

Always check that the fastening clips are secured and correctly positioned prior to lifting the patient/resident!

8.1.2.2 Safely attaching the slings



Step 1

Carefully lower the spreader bar by pressing the “down” button of the hand control, until you can slide the slings over the attachment hooks.

Step 2

Pull the sling over the attachment hook.

Step 3

Make sure that the sling is pulled to the end of the attachment hook (refer to “Final position”)!

Always check that the clips or the slings are secured and located in the right position before your start lifting your patient!

8.1.3 After use

As the washing process is regarded, the slings are classified as accessory of the sit-to-stand lift and therefore as medical device. The slings may only be cleaned and disinfected in accordance with the manufacturer's instructions.

During the washing and drying, no mechanical pressure must be applied, such as dry press, rotary iron. This could damage the sling parts and impair the operation and the safety of the sling or even destroy the sling.

The sling straps and the slings must be checked and, if required, cleaned after each use. The washing temperatures must not exceed the temperature specified on the sling (60 °C). Please use common household detergents only. Do not iron hot. The plastic clips must be checked for possible damages after each wash.

8.2 Raising the patient from a chair or the bed (sitting position)

CAUTION



Each lifting or transfer procedure must be adequately planned to ensure an optimal protection for the caregiver and the resident.

- Lift the patient/resident into a safe standing position and make the transfer as short as possible.
- Avoid slippery surfaces and thresholds and do not move the product over sloping or uneven floors.
- Make sure that the resident is not hurt by the door frame when passing through doors.

CAUTION



Activate the brakes of the castors of the wheelchair, the healthcare bed, the stretcher, etc. to ensure a safe lifting and positioning of the resident.

To transfer a patient / resident from a chair or bed (sitting position of the patient), proceed as follows (see also illustrations under point 8.3):

1. To raise the patient/resident from the bed, set the patient upright in the bed and turn him/her so that the feet touch the ground, and the patient has a stable sitting position.
2. Wrap the backside of the sling around the patient/resident and fasten the clip fastener of the belly part. Please make sure to use the correct sling size adjusted to the patient and check that the patient's arms are located outside the sling.
3. Spread the legs of the carrier frame and lower the spreader bar completely.
4. Position the NORA in front of the patient and adjust it so that the patient's legs are resting on the 3D-Comfort-System and form a right angle with the thighs. The patient's feet must be located in the middle of the footplate.
5. Activate the brakes on the rear castors.
6. Tighten and fasten the two leg safety belts.
7. Raise the spreader bar to the required height to attach the sling to the sling attachment points of the spreader bar.
8. Suspend the sling in the sling attachment points. Please check that the sling is correctly attached (also refer to section 8.1.2.1 Safely suspending the clips in the

holder).

CAUTION



- Check prior to lifting that all clips or loops are correctly fixed to the spreader bar.
- Make sure that the patient seizes the handles provided to that effect with both hands.
- Make sure that no one grabs in the hazardous areas (bracket, carrier frame) during the adjustment procedure. - Risk of crushing.
- Check before and during the height adjustment procedure that your feet are not located in the area of the castors or in the resident's area.

9. You can now raise the patient/resident.

CAUTION



- Do not stand between the sit-to-stand lift and an obstacle during the transfer procedure.
- During the movement of the sit-to-stand lift, the carrier frame must be closed.

10. The steering of the NORA is enhanced when the carrier frame is not spread.

11. Release the brakes to transfer the patient/resident.

8.3 Raising the patient from a wheelchair

CAUTION



Each lifting or transfer procedure must be adequately planned to ensure an optimal protection for the caregiver and the resident.

- Lift the patient/resident into a safe standing position and make the transfer as short as possible.
- Avoid slippery surfaces and thresholds and do not move the product over sloping or uneven floors.
- Make sure that the resident is not hurt by the door frame when passing through doors.

CAUTION



Activate the brakes of the castors of the wheelchair, the healthcare bed, the stretcher, etc. to ensure a safe lifting and positioning of the resident.

Please proceed in the following way to raise a patient from a wheelchair:

1. Engage the parking brakes of the wheelchair.
2. Wrap the backside of the sling around the patient/resident and fasten the clip fastener of the belly part. Please make sure to use the correct sling size adjusted to the patient and check that the patient's arms are located outside the sling.
3. Spread the legs of the carrier frame and lower the spreader bar completely.
4. Position the NORA in front of the patient and adjust it so that the patient's legs are resting on the 3D-Comfort-System and form a right angle with the thighs. The patient's feet must be located in the middle of the footplate.
5. Activate the brakes on the rear castors.
6. Tighten and fasten the two leg safety belts.
7. Raise the spreader bar to the required height to attach the sling to the sling attachment points of the sling bow.
8. Suspend the sling in the sling attachment points. Please check that the sling is correctly attached (also refer to section 8.1.2.1 Safely suspending the clips in the holder).

CAUTION



- Check prior to lifting that all clips or loops are correctly fixed to the spreader bar.
- Make sure that the patient seizes the handles provided to that effect with both hands.
- Make sure that no one grabs in the hazardous areas (bracket, carrier frame) during the adjustment procedure. - Risk of crushing.
- Check before and during the height adjustment procedure that your feet are not located in the area of the castors or in the resident's area.

9. You can now raise the patient/resident.

CAUTION



- Do not stand between the sit-to-stand lift and an obstacle during the transfer procedure.
- During the movement of the sit-to-stand lift, the carrier frame must be closed.

10. The steering of the NORA is enhanced when the carrier frame is not spread.

11. Release the brakes to transfer the patient/resident.



Preparation for lifting



Lifting the patient / resident



Transferring the patient / resident

8.4 Putting the patient/resident down

When you have reached the desired location, you can put the patient/resident e.g. on a chair or in bed. Proceed in the following manner:

1. Spread the carrier frame if needed up to the maximum possible spread width.
2. Bring the sit-to-stand lift with the patient/resident over the intended location.
3. Check that the chair or the bed stands safely; activate the brakes of the wheelchair if required.
4. Lower the lifting arm with the spreader bar until the patient/resident sits safely in the chairs or on the bed and the loops of the sling are relieved.
5. Remove the loops or the clips of the sling from the spreader bar.
6. Pull the sit-to-stand lift away from the patient. Make sure to pull the sit-to-stand lift straight backwards to avoid injuring the patient with the spreader bar. If required, raise the spreader bar to avoid injury of the patient/resident.
7. Put the sit-to-stand lift at a safe location.
8. Remove the sling from the patient/resident.

8.5 Operation of the sit-to-stand lift

The spreader bar and the carrier frame of the NORA sit-to-stand lift are operated by means of the control panel or the hand control, which is included in the delivery. The direction of motion is indicated by symbols.

Rising and lowering of the spreader bar



Buttons of the hand control



Buttons of the control panel

Keep the button  of the hand control or the control panel pressed to raise the spreader bar. The spreader bar is raised. Release the button as soon as the spreader bar has reached the desired position. The upward movement of the spreader bar is stopped.

When the highest possible position is reached, the upward movement is automatically stopped.

Keep the button  of the hand control or the control panel pressed to lower the spreader bar. The spreader bar is lowered. Release the button as soon as the spreader bar has reached the desired position. The downward movement of the spreader bar is stopped.

When the lowest possible position is reached, the downward movement is automatically stopped.

Display maximum weight



When the LED display next to the weight symbol of the hand control lights up, the maximum possible lifting weight of the NORA sit-to-stand lift has been reached. The weight symbol with the signature "Overload" also appears on the display on the control unit.

In such case, lower the patient and use another sit-to-stand lift with a higher load capacity.

Spreading the carrier frame



Buttons of the hand control



Buttons of the control panel

Keep the button  of the hand control pressed to spread the carrier frame. The chassis of the sit-to-stand lift is spread. Release the button as soon as the desired spread width is reached. The spreading movement is stopped. When the maximum spreading position is reached, the movement is automatically stopped.

Keep the button  of the hand control pressed to close the carrier frame. The chassis of the sit-to-stand lift is fold. Release the button as soon as the desired spread width is reached. The spreading movement is stopped. When the minimum spreading position is reached, the movement is automatically stopped.

The spreadable chassis highly increases the stability of the sit-to-stand lift.

Travel path

When using the NORA sit-to-stand lift, make sure that the travel path is not narrowed by obstacles or other elements (e.g. wall racks, etc.).

Caution

The NORA sit-to-stand lift is exclusively fit for indoor use.

Caution

Do not move the NORA sit-to-stand lift over sloping or uneven floors.

Warning

Make sure that the sit-to-stand lift is not tilted over 5° when driving over thresholds or similar. The sit-to-stand lift could fall over!

8.6 Operation of the leg separator (option)

The optional, detachable and attachable NORA Pro leg separator helps to keep the patient's/resident's knees and legs apart so that they do not rub against each other, and one has better access to all care areas. In particular, it makes it easier for the nursing staff to change nappies and other aids.

The leg separator is attached to the 3D-Comfort-System from above and can be removed again by pulling it slightly upwards (see photo in chapter 7.10).



8.7 Maintenance and care of the battery

The battery and the control box must not be opened by the customer.

Repairs may be carried out only either by BEKA Hospitec or by companies authorized to this effect by BEKA Hospitec. If the battery is discharged, recharge it as soon as possible to extend the lifetime.

Batteries stored in the warehouse/stock must be recharged every 6 months. The battery's lifetime basically depends on the charge (number of lifting cycles) and the charging state. Have defective or worn-out batteries, and defective charging units replaced.

9 Cleaning / disinfection

<p>CAUTION</p> 	<p>Cleaning and disinfection are only allowed without patient presence! Make sure that the system is not in operation during the cleaning activities.</p>
<p>CAUTION</p> 	<p>After each treatment, the product must be completely disinfected with a disinfectant. In this way, any cross-contamination is avoided.</p>
<p>CAUTION</p> 	<p>Only use the disinfectant after the patient has left the product. Strictly respect and observe the manufacturer's instructions for the used disinfectant. Avoid direct contact with the concentrated product. If necessary, use gloves and safety glasses to protect your skin and eyes.</p>

9.1 Cleaning the sit-to-stand lift

Clean the device with a soft, lint-free cloth, moistened with a mild soap solution or a normal cleaning agent for plastics. Do not use scouring agents or other aggressive cleaning agents and disinfectants!

Grease stains, residues of skin and hair can be removed with a sponge and soap. Please do not use abrasives to clean the sit-to-stand lift!

To avoid damages, **no** aerosol cleaners, sprays, abrasive cleaners or solvents must be used to clean the control unit. Please remember that all warranty claims regarding surface damage will not be accepted, if aggressive cleaning agents are anyhow used.

Make sure that no liquids get into the housing, motor, control unit or battery of the device during cleaning and disinfection!

9.2 Disinfecting the sit-to-stand lift

You must carefully disinfect and rinse your sit-to-stand lift after each use to avoid the risk of transmission and infection. For the manual disinfection of the surface, an isopropyl alcohol solution or a customary disinfection aerosol (spray) can be used.

9.3 Sterilising the sit-to-stand lift

The NORA sit-to-stand lift is **not** suitable for sterilisation.

10 Maintenance, safety checks and servicing

In order to ensure a safe use of the NORA Pro and for the protection of users and patients, the product must be subjected to regular inspections and maintenance as well as to an annual safety check. This includes, among other things, a visual inspection for external damage (housing, mains connections, legible labelling, soiling, etc.) as well as availability and completeness of the documentation.

The execution of the safety checks and maintenance must be documented and proven on request. Please use your inventory register to this effect.

Inspections, maintenance and checks may only be conducted by trained and qualified experts authorized by the manufacturer, who meet the requirements according to your applicable national / local regulations. Non-observance may result in injuries or an unsafe product.

In case of doubt, please contact your supplier or manufacturer.

<p>NOTE</p> 	<p>In accordance with the UVV (accident prevention) regulations of the German employer's liability insurance association on mobile equipment which is used in special locations or installations, the product must be subject to an annual check to the DGUV (German Statutory Accident Insurance Association) Prescription 3</p>
---	---

This check is only prescribed for Germany. In other countries, other requirements might be applicable.

<p>WARNING</p> 	<p>Do not conduct any cleaning, maintenance or test activities when the product is in use. This could cause danger to the user and the patient. Installation, maintenance, servicing and testing activities are only permitted without the patient being present.</p>
---	---

Clean and disinfect the product **every day**.

Conduct a **weekly** visual inspection of all components, the power cable and the connections. Conduct a functional test as well and clean the castors if necessary.

Conduct **every year** a maintenance, a safety check and a check to DGUV prescription 3.

10.1 Prior to each use

To ensure a safe and failure-free operation, the following checks must be carried out prior to each use:

- Visual check of the sit-to-stand lift (external damages and wear-and-tear).
- Check that no screws of the sit-to-stand lift are missing or loose.
- Perform a functional check of the sit-to-stand lift.
- Check the proper functioning of the spreader bar.
- Check the proper functioning of the hand control (up/down, spreading).
- Check the emergency lowering system.
- Check the smooth running of the castors.
- Check the slings for damages.
- Check the state of charge of the battery.
- Check the function of the leg safety belts.

11 Environmental protection / waste disposal

The manufacturer is aware of the responsibility towards the environment. The product must not be disposed of with household waste!

11.1 Disposal of the packaging material

Please recycle the packaging materials of the product in accordance with the locally applicable regulations and laws. The metal parts as well as the plastic and electronic components must be recycled in accordance with the WEEE.

11.2 Disposal of the product

The expected operating lifetime of the NORA Pro is approx. 10 years. At the end of the product's lifetime, contact your BEKA dealer, who will recycle the product in accordance with the locally applicable regulations and laws. For an environmentally-sound disposal, the company BEKA Hospitec GmbH will provide more information in its capacity of manufacturer.

According to WEEE, the manufacturer takes back all equipment placed on the market by him for the purpose of proper disposal. Please contact us in this regard if necessary and inform your customers in case of resale.

Please clean and disinfect the product prior to its disposal as well.

12 Troubleshooting / After-sales service

Problems with the NORA Alu	Remedy
<p>The height adjustment and the spreading of the carrier frame of the NORA Pro do not function.</p>	<ul style="list-style-type: none"> a) Check if the emergency stop switch is released or pressed. b) Check that the cables of the control box are correctly plugged in. c) Check the battery's charging state. d) Remove the battery and check the contacts for damage. e) When hitting an obstacle, first press the "Up" button.
<p>The spreader bar remains in the top end position.</p>	<ul style="list-style-type: none"> a) Check if the emergency stop switch is released or pressed. b) Check the battery's charging state. c) Use the mechanical emergency lowering feature (see 7.5) to lower the patient/resident. d) Push the "down" button on the hand control and simultaneously press down the bow. Contact the after-sales service.
<p>The carrier frame motor does not run.</p>	<ul style="list-style-type: none"> a) Check if the emergency stop switch is released or pressed. b) Check that the control box is correctly plugged in. c) Check the battery's charging state (replace with fully charged battery).
<p>Heavy going, sluggish operation of the drive despite fully charged battery.</p>	<ul style="list-style-type: none"> a) Battery low. Charge the battery. b) The maximum load is exceeded (max. patient weight). c) The battery has reached the end of its lifetime. Replace the battery.
<p>The control box emits a "beep" signal when operated.</p>	<p>Battery low. Charge the battery.</p>
<p>The hand control does not work.</p>	<ul style="list-style-type: none"> a) Check the connector at the cable of the hand control. b) Check the battery's charging state (replace with fully charged battery). c) Operation via the control box control panel.
<p>The up and down buttons of the hand control do not respond.</p>	<ul style="list-style-type: none"> a) Check if the emergency stop switch is released or pressed. b) Check the battery's charging state (replace with fully charged battery). c) Check that the cables of the control box are correctly plugged in.
<p>The castors produce loud noises.</p>	<p>Clean or replace the castors.</p>
<p>The NORA Pro produces unusual noises.</p>	<p>Inform the after-sales service.</p>

The NORA Pro is damaged.	Inform the after-sales service.
The orange Service LED on the hand control flashes.	Safety check required, inform the after-sales service.
Problems with the charging unit	Remedy
The charging unit does not work.	a) Remove the battery pack and check the contacts for damage. b) Check the mains plug.
The charging unit is connected to the power outlet, but the operating display is not lit.	a) Check that the charging unit is connected to a power outlet. b) Check that the power outlet is supplied with power. c) Check the power outlet fuse. d) Remove the battery and check for damage.
Problems with the battery	Remedy
The battery is placed correctly, but the indicator lights are not lit.	Inform the after-sales service.
The indicator light does not go out after multiple hours of charging.	The battery must be replaced. Inform the after-sales service.
The battery installed in the charging unit indicates that it is fully charged. However, when placed in the NORA Pro, just a few lifting cycles are possible.	The battery must be replaced. Inform the after-sales service.
When the hand control is actuated, an acoustic signal is emitted, and the indicator light (red) is on.	Check the battery's charging state.

When your product does not function properly and you cannot eliminate the error by means of the remedies listed in paragraph 12, please contact the customer service of your dealer either the manufacturer.

	BEKA Hospitec GmbH Am Rübenmorgen 3 35582 Wetzlar Phone: +49(0)641-9 22 20-0 Fax: +49(0)641-9 22 20-20 info@beka-hospitec.de
---	---

13 Appendix

13.1 Technical description

Sit-to-stand lift:

Electrical data	
- Applied part:	type B
- Protection class:	II
- Voltage supply:	25 V DC battery
- Power consumption:	max. 240 VA
- Insulation distance:	2 MOPP
Dimensions and weights	
- Length:	994 mm
- Width in closed condition (internal dimension):	543 mm
- External width of the closed carrier frame:	703 mm
- Width in open condition (internal dimension):	910 mm
- External width of the spread carrier frame:	1063 mm
- External width at the handle:	704 mm
- Min. height:	1091 mm
- Max. height:	1659 mm
- Turning radius:	1263 mm
- Weight without packaging:	50 kg
- Safe Working Load (SWL):	max. 205 kg (Nora Pro)
IP degree of protection	
- Sit-to-stand lift	IPX4
- Hand control	IPX6
Operating mode	
- Operating mode (height adjustment):	non-continuous operation
- Duty cycle (motor):	max. 2 min ON, then min.18 min OFF
Operating force of the control device:	max. 5 N
Sound power level:	max. 50 dB

Ambient conditions

Operation	
- Temperature range:	10 °C to 40 °C (50 °F to 104 °F)
- Relative humidity:	30% to 75%, non-condensing
- Atmospheric pressure:	80 kPa - 106 kPa
- Operation in oxygen-enriched atmosphere:	not provided
- Sterilization:	not provided
Storage and transport	
- Temperature range (lift):	-40 °C to 70 °C (-40 °F to 158 °F)
- Temperature range (battery):	-10 °C to 40 °C (14 °F to 104 °F)
- Relative humidity:	10% to 80%, non-condensing
- Atmospheric pressure:	86 kPa - 110 kPa

Battery charger:

- Input voltage:	100 V - 240 V~ (AC) / 50 / 60 Hz
- Output voltage:	25 V (DC)
- Power consumption:	I in max. 0.8 A
- Fuse	T1.25 / 250 V
- Protection class:	IPX4

Battery:

- Battery type:	Lithium-ion battery
- Output voltage:	25 V (DC)
- Capacity	4.3 Ah
- Output current:	I out max 13 A
- Protection class:	IPX6

13.2 Dimensions of the NORA Pro

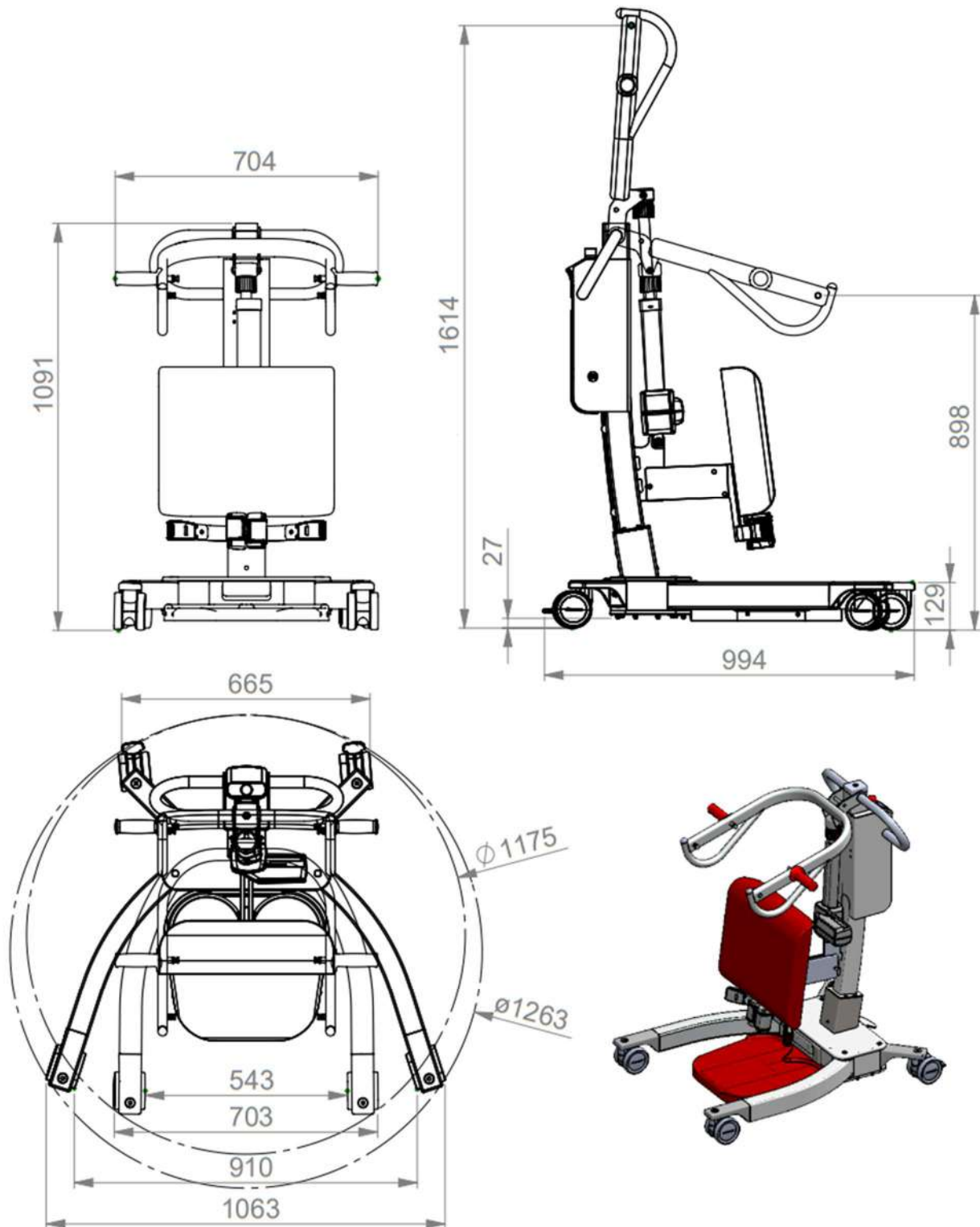

13.3 Connection and assembly diagram

Observe the information given in chapter 6 Installation.

13.4 Declaration of Conformity



EU-Konformitätserklärung / EU-Declaration of Conformity

Der Hersteller / The manufacturer

BEKA Hospitec GmbH, Am Rübenmorgen 3, D-35582 Wetzlar-Dutenhofen

SRN: DE-MF-000013895

erklärt in alleiniger Verantwortung gemäß Verordnung (EU) Medizinprodukte 2017/745 des Europäischen Parlaments und des Rates vom 5. April 2017 über Medizinprodukte MDR, Kapitel V, Abschnitt 2, Artikel 52, Unterabsatz 7, dass die folgenden

BEKA Lifter / Aufstehhilfe und deren Zubehör

declares under sole responsibility according to the Regulation (EU) Medical Devices 2017/745 of the European Parliament and of the Council of 5 April 2017 on medical devices MDR, Chapter V, Section 2, Article 52, subparagraph 7, that the following

BEKA Lifts / Sit-to-stand lifts and their accessories

Basis-UDI-DI: 426068189120BM

Produkt / Product	Artikel Nr. / P/N.
NORA	921071000W
NORA Alu / NORA Alu low	921071000, 921071008, 921071018, 921074008, 921074018, 921076000
NORA Comfort	921077000
NORA ECO / NORA ECO BRAUS	921075000, 921075000B, 921075500
NORA Select	921070000W
NORA Pro	921077000, 921078000
Aufstehhilfe Clara	921073000

den grundlegenden Sicherheits- und Leistungsanforderungen entsprechen und die Voraussetzungen für die CE-Kennzeichnung erfüllen
comply with the general safety and performance requirements and fulfill the provisions of CE marking

Die Produkte & deren Zubehöre entsprechen Klasse I, Verordnung (EU) Medizinprodukte 2017/745, Anhang VIII, Kapitel III, Regel 1&13
The products & their accessories correspond with Class I, Regulation (EU) Medical Devices 2017/745, Annex VIII, Chapter III, Rule 1&13

Produktrealisierung und Prüfung gemäß den folgenden Normen und Richtlinien:

Testing according to the following standards and directives:

Verordnung (EU) „Medizinprodukte“ 2017/745 Regulation (EU) "Medical Devices" 2017/745, MDR	DIN EN 60601-1:2006 + Cor.:2010 + A1:2013 * IEC 60601-1:2005 + Cor.:2006 + Cor.:2007 + A1:2012
DIN EN 12182:2012 / EN 12182:2012	ANSI/AAMI ES60601-1:2005/(R)2012 * CAN/CSA-C22.2 NO. 60601-1:14 *
DIN EN ISO 12100:2011 & Berichtigung 1:2013 / ISO 12100:2010	DIN EN 60601-1-2:2016 / IEC 60601-1-2:2014
DIN EN ISO 13857:2020 / ISO 13857:2019	DIN EN 60601-1-6:2021 / IEC 60601-1-6:2010 + A1:2013 + A2:2020
DIN EN ISO 13854:2020 / ISO 13854:2019	DIN EN 62366-1:2021 / IEC 62366-1:2015 + COR1:2016 + A1:2020
RoHS Richtlinie / Directive 2011/65/EU & 2015/863/EU REACH Verordnung / Regulation EU 1907/2006	DIN EN ISO 14971:2020 / ISO 14971:2019
Richtlinie / Directive 2006/42/EG Richtlinie / Directive 2012/19/EU - WEEE:2012-07-04	DIN EN ISO 10535:2007 / ISO 10535:2006 * DIN EN ISO 3758:2012

Diese Erklärung trifft auf alle Produkte zu, die nach Ausstellung dieser Erklärung produziert wurden, bis sie durch eine andere Erklärung ersetzt wird. / This declaration applies to all CE marked devices manufactured from the date of its issuance on until it is either superseded by another declaration or withdrawn.

Technische Änderungen vorbehalten / Technical changes reserved

*: TÜV SÜD Certificate for Canada and USA for specific article numbers

Wetzlar, den 04.02.2022

Robert Deschler
Geschäftsführer / Managing Director

BEKA Hospitec GmbH
Am Rübenmorgen 3
D-35582 Wetzlar-Dutenhofen
Fon 0641 / 92 22 0-0
Fax 0641 / 92 22 0-20

USt-IdNr.: DE278603356
Amtsgericht Wetzlar, HRB 6207
info@beka-hospitec.de
www.beka-hospitec.de

Geschäftsführung
James Stuart-Smith
Robert Deschler

Commerzbank AG Wetzlar
Konto-Nr.: 482176500
BLZ: 515 400 37
IBAN: DE60515400370482176500
SWIFT-BIC: COBADEFF515

Seite 1 von 1

EU-Konformitätserklärung / EU-Declaration of Conformity

Der Hersteller / The manufacturer

BEKA Hospitec GmbH, Am Rübenmorgen 3, D-35582 Wetzlar-Dutenhofen

SRN: DE-MF-000013895

erklärt in alleiniger Verantwortung gemäß Verordnung (EU) Medizinprodukte 2017/745 des Europäischen Parlaments und des Rates vom 5. April 2017 über Medizinprodukte MDR, Kapitel V, Abschnitt 2, Artikel 52, Unterabsatz 7, dass die folgenden

BEKA Gurte – Lifter Zubehöre

declares under sole responsibility according to the Regulation (EU) Medical Devices 2017/745 of the European Parliament and of the Council of 5 April 2017 on medical devices MDR, Chapter V, Section 2, Article 52, subparagraph 7, that the following

BEKA Slings – Lift Accessories

Basis-UDI-DI: 426068189119C4

Gurt / Sling	Artikel Nr. / P/N.	Gurt / Sling	Artikel Nr. / P/N.
Transfurgurt XS mit Clip / Transfer sling XS with clips	922005050D, 922005050	Toilettengurt M mit Schlaufen /Toilet sling M with loops	923005200
Transfurgurt XS mit Clip / Transfer sling XS with clips	922005100D, 922005100, 922003103, 922005103US	Toilettengurt L mit Schlaufen /Toilet sling L with loops	923005300
Transfurgurt M mit Clip / Transfer sling M with clips	922005200D, 922005200, 922003203, 922005203US	Toilettengurt XL mit Schlaufen /Toilet sling XL with loops	923005400
Transfurgurt L mit Clip / Transfer sling L with clips	922005300D, 922005300, 922003303, 922005303US	Toilettengurt XXL mit Schlaufen /Toilet sling XXL with loops	923005500
Transfurgurt XL mit Clip / Transfer sling XL with clips	922005400D, 922005400, 922003403, 922005403US	Softgurt S mit Clip / Soft sling S with clips	922005110D, 922005110
Transfurgurt XXL mit Clip / Transfer sling XXL with clips	922005500D, 922005500, 922003503, 922005503US	Softgurt M mit Clip / Soft sling M with clips	922005210D, 922005210
Transfurgurt S mit Clip +10 cm / Transfer sling S with clips +10 cm	922005113, 922005113US	Softgurt L mit Clip / Soft sling L with clips	922005310D, 922005310
Transfurgurt M mit Clip +10 cm / Transfer sling M with clips +10 cm	922005213, 922005213US	Softgurt XL mit Clip / Soft sling XL with clips	922005410D, 922005410
Transfurgurt L mit Clip +10 cm / Transfer sling L with clips +10 cm	922005313, 922005313US	Softgurt XXL mit Clip / Soft sling XXL with clips	922005510D, 922005510
Transfurgurt XL mit Clip +10 cm / Transfer sling XL with clips +10 cm	922005413, 922005413US	Softgurt S mit Clip für beidseitig Amputierte / Soft sling S with clips for double leg amputees	922005127D, 922005127
Transfurgurt XXL mit Clip +10 cm / Transfer sling XXL with clips +10 cm	922005513, 922005513US	Softgurt M mit Clip für beidseitig Amputierte / Soft sling M with clips for double leg amputees	922005227D, 922005227
Transfurgurt XS mit Schlaufen / Transfer sling XS with loops	923003050	Softgurt L mit Clip für beidseitig Amputierte / Soft sling L with clips for double leg amputees	922005327D, 922005327
Transfurgurt S mit Schlaufen / Transfer sling S with loops	923003100	Softgurt XL mit Clip für beidseitig Amputierte / Soft sling XL with clips for double leg amputees	922005427D, 922005427
Transfurgurt M mit Schlaufen / Transfer sling M with loops	923003200	Softgurt XXL mit Clip für beidseitig Amputierte / Soft sling XXL with clips for double leg amputees	922005527D, 922005527
Transfurgurt L mit Schlaufen / Transfer sling L with loops	923003300	Softgurt S mit Schlaufen / Soft sling S with loops	923003110
Transfurgurt XL mit Schlaufen / Transfer sling XL with loops	923003400	Softgurt M mit Schlaufen / Soft sling M with loops	923003210
Transfurgurt XXL mit Schlaufen / Transfer sling XXL with loops	923003500	Softgurt L mit Schlaufen / Soft sling L with loops	923003310
Transfurgurt S mit Schlaufen Sonderausführung / Transfer sling S with loops, special design	923003101	Softgurt XL mit Schlaufen / Soft sling XL with loops	923003410
Transfurgurt M mit Schlaufen Sonderausführung / Transfer sling M with loops, special design	923003201	Softgurt XXL mit Schlaufen / Soft sling XXL with loops	923003510
Transfurgurt XL mit Schlaufen Sonderausführung / Transfer sling XL with loops, special design	923003401	Transfurgurt S mit Clip für beidseitig Amputierte / Transfer sling S with clips for double leg amputees	922005117D, 922005117, 922005117US

BEKA Hospitec GmbH
Am Rübenmorgen 3
D-35582 Wetzlar-Dutenhofen
Fon 0641 / 92 22 0-0
Fax 0641 / 92 22 0-20

USt-IdNr.: DE278603356
Amtsgericht Wetzlar, HRB 6207
info@beka-hospitec.de
www.beka-hospitec.de

Geschäftsführung
James Stuart-Smith
Robert Deschler

Commerzbank AG Wetzlar
Konto-Nr.: 482176500
BLZ: 515 400 37
IBAN: DE60515400370482176500
SWIFT-BIC: COBADEFF515

Seite 1 von 3

Badegurt XS mit Clip / Bathing sling XS with clips	922006050D, 922006050	Transfurgurt M mit Clip für beidseitig Amputierte / Transfer sling M with clips for double leg amputees	922005217D, 922005217, 922005217US
Badegurt S mit Clip / Bathing sling S with clips	922006100D, 922006100, 922006103, 922006103US	Transfurgurt L mit Clip für beidseitig Amputierte / Transfer sling L with clips for double leg amputees	922005317D, 922005317, 922005317US
Badegurt M mit Clip / Bathing sling M with clips	922006200D, 922006200, 922006203, 922006203US	Transfurgurt XL mit Clip für beidseitig Amputierte / Transfer sling XL with clips for double leg amputees	922005417D, 922005417, 922005417US
Badegurt L mit Clip / Bathing sling L with clips	922006300D, 922006300, 22006303, 922006303US	Transfurgurt XXL mit Clip für beidseitig Amputierte / Transfer sling XXL with clips for double leg amputees	922005517D, 922005517, 922005517US
Badegurt XL mit Clip / Bathing sling XL with clips	922006400D, 922006400, 922006403, 922006403US	Transfurgurt S mit Clip für einseitig Amputierte links / Transfer sling S with clips for single leg amputees, left	922005130L
Badegurt XXL mit Clip / Bathing sling XXL with clips	922006500D, 922006500, 922006503, 922006503US	Transfurgurt M mit Clip für einseitig Amputierte links / Transfer sling M with clips for single leg amputees, left	922005230L
Badegurt S mit Clip +10 cm / Bathing sling S with clips +10 cm	922006113, 922006113US	Transfurgurt L mit Clip für einseitig Amputierte links / Transfer sling L with clips for single leg amputees, left	922005330L
Badegurt M mit Clip +10 cm / Bathing sling M with clips +10 cm	922006213, 922006213US	Transfurgurt XL mit Clip für einseitig Amputierte links / Transfer sling XL with clips for single leg amputees, left	922005430L
Badegurt L mit Clip +10 cm / Bathing sling S with clips +10 cm	922006313, 922006313US	Transfurgurt XXL mit Clip für einseitig Amputierte links / Transfer sling XXL with clips for single leg amputees, left	922005530L
Badegurt S mit Clip +10 cm / Bathing sling L with clips +10 cm	922006413, 922006413US	Transfurgurt S mit Clip für einseitig Amputierte rechts / Transfer sling S with clips for single leg amputees, right	922005130R
Badegurt XL mit Clip +10 cm / Bathing sling XL with clips +10 cm	922006513, 922006513US	Transfurgurt M mit Clip für einseitig Amputierte rechts / Transfer sling M with clips for single leg amputees, right	922005230R
Badegurt XS mit Schlaufen / Bathing sling XS with loops	923004050	Transfurgurt L mit Clip für einseitig Amputierte rechts / Transfer sling L with clips for single leg amputees, right	922005330R
Badegurt M mit Schlaufen / Bathing sling S with loops	92304100	Transfurgurt XL mit Clip für einseitig Amputierte rechts / Transfer sling XL with clips for single leg amputees, right	922005430R
Badegurt M mit Schlaufen / Bathing sling M with loops	923004200	Transfurgurt XXL mit Clip für einseitig Amputierte rechts / Transfer sling XXL with clips for single leg amputees, right	922005530R
Badegurt L mit Schlaufen / Bathing sling L with loops	923004300	Aufrichtgurt S mit Clip / Stand-up/raising sling S with clips	921070050D, 921070050, 921070053, 921070053US
Badegurt XL mit Schlaufen / Bathing sling XL with loops	923004400	Aufrichtgurt M mit Clip / Stand-up/raising sling M with clips	921070100D, 921070100, 921070103, 921070103US
Badegurt XXL mit Schlaufen / Bathing sling XXL with loops	923004500	Aufrichtgurt L mit Clip / Stand-up/raising sling L with clips	921070200D, 921070200, 921070203, 921070203US
Toilettengurt M mit Clip / Toilet sling M with clips	922007200D, 922007200, 922007203, 922007203US	Aufrichtgurt XL mit Clip / Stand-up/raising sling XL with clips	921070300D, 921070300, 921070303, 921070303US
Toilettengurt L mit Clip / Toilet sling L with clips	922007300D, 922007300, 922007303, 922007303US	Aufrichtgurt XXL mit Clip / Stand-up/raising sling XXL with clips	921070500D+921070500
Toilettengurt XL mit Clip / Toilet sling XL with clips	922007400D, 922007400, 922007403, 922007403US	Aufrichtgurt S mit Schlaufen / Stand-up/raising sling S with loops	921071050
Toilettengurt XXL mit Clip / Toilet sling XXL with clips	922007500D, 922007500	Aufrichtgurt M mit Schlaufen / Stand-up/raising sling M with loops	921071100
Toilettengurt M mit Clip +10 cm / Toilet sling M with clips +10 cm	922007213, 922007213US	Aufrichtgurt L mit Schlaufen / Stand-up/raising sling L with loops	921071200
Toilettengurt L mit Clip +10 cm / Toilet sling L with clips +10 cm	922007313, 922007313US	Aufrichtgurt XL mit Schlaufen / Stand-up/raising sling XL with loops	921071300

BEKA Hospitec GmbH
 Am Rübenmorgen 3
 D-35582 Wetzlar-Dutenhofen
 Fon 0641 / 92 22 0-0
 Fax 0641 / 92 22 0-20

US1-IdNr.: DE278603356
 Amtsgericht Wetzlar, HRB 6207
 info@beka-hospitec.de
 www.beka-hospitec.de

Geschäftsführung
 James Stuart-Smith
 Robert Deschler

Commerzbank AG Wetzlar
 Konto-Nr.: 482176500
 BLZ: 515 400 37
 IBAN: DE60515400370482176500
 SWIFT-BIC: COBADEFF515

Seite 2 von 3

Toilettengurt XL mit Clip +10 cm / Toilet sling XL with clips +10 cm	922007413, 922007413US	Aufrichtgurt XXL mit Schlaufen / Stand- up/raising sling XXL with loops	921071350
Sicherungsgurt für Liege/Sitz / Security Belt for Patient Hoist		920603221	

den grundlegenden Sicherheits- und Leistungsanforderungen entsprechen und die Voraussetzungen für die CE-Kennzeichnung erfüllen
comply with the general safety and performance requirements and fulfill the provisions of CE marking
 Die Produkte & deren Zubehör entsprechen Klasse I, Verordnung (EU) Medizinprodukte 2017/745, Anhang VIII, Kapitel III, Regel 1&13
The products & their accessories correspond with Class I, Regulation (EU) Medical Devices 2017/745, Annex VIII, Chapter III, Rule 1&13
 Produktrealisierung und Prüfung gemäß den folgenden Normen und Richtlinien:
Testing according to the following standards and directives:

Verordnung (EU) „Medizinprodukte“ 2017/745 Regulation (EU) "Medical Devices" 2017/745, MDR	DIN EN 60601-1:2006 + Cor.:2010 + A1:2013 * IEC 60601-1:2005 + Cor.:2006 + Cor.:2007 + A1:2012
DIN EN 12182:2012 / EN 12182:2012	ANSI/AAMI ES60601-1:2005/(R)2012 * CAN/CSA-C22.2 NO. 60601-1:14 *
DIN EN ISO 12100:2011 & Berichtigung 1:2013 / ISO 12100:2010	DIN EN 60601-1-2:2016 / IEC 60601-1-2:2014
DIN EN ISO 13857:2020 / ISO 13857:2019	DIN EN 60601-1-6:2021 / IEC 60601-1-6:2010 + A1:2013 + A2:2020
DIN EN ISO 13854:2020 / ISO 13854:2019	DIN EN 62366-1:2021 / IEC 62366-1:2015 + COR1:2016 + A1:2020
RoHS Richtlinie / Directive 2011/65/EU & 2015/863/EU REACH Verordnung / Regulation EU 1907/2006	DIN EN ISO 14971:2020 / ISO 14971:2019
Richtlinie / Directive 2006/42/EG Richtlinie / Directive 2012/19/EU - WEEE:2012-07-04	DIN EN ISO 10535:2007 / ISO 10535:2006 * DIN EN ISO 3758:2012

Diese Erklärung trifft auf alle Produkte zu, die nach Ausstellung dieser Erklärung produziert wurden, bis sie durch eine andere Erklärung ersetzt wird. / *This declaration applies to all CE marked devices manufactured from the date of its issuance on until it is either superseded by another declaration or withdrawn.*

Technische Änderungen vorbehalten / Technical changes reserved

*: TÜV SÜD Certificate for Canada and USA for specific article numbers

Wetzlar, den 04.02.2022



.....
 Robert Deschler
 Geschäftsführer / Managing Director

BEKA Hospitec GmbH
 Am Rübenmorgen 3
 D-35582 Wetzlar-Dutenhofen
 Fon 0641 / 92 22 0-0
 Fax 0641 / 92 22 0-20

USt.-IdNr.: DE278603356
 Amtsgericht Wetzlar, HRB 6207
 info@beka-hospitec.de
 www.beka-hospitec.de

Geschäftsführung
 James Stuart-Smith
 Robert Deschler

Commerzbank AG Wetzlar
 Konto-Nr.: 482176500
 BLZ: 515 400 37
 IBAN: DE60515400370482176500
 SWIFT-BIC: COBADEFF515

Seite 3 von 3

13.5 Additional equipment, accessories, and spare parts

Accessories / options	Description	Article no.
Detachable leg separator	For attaching to the leg pad	921077100
Spare battery 25 V	NORA Pro	921077400
External charger	NORA Pro	921077300
Raising sling NORA Pro	Size S	921078010 921078010D
Raising sling NORA Pro	Size M	921078020 921078020D
Raising sling NORA Pro	Size L	921078030 921078030D
Raising sling NORA Pro	Size XL	921078040 921078040D
Raising sling NORA Pro	Size XXL	921078050 921078050D

For Germany, the article numbers ending with "D" apply.

Guidelines for sling sizes

NORA standing/raising sling with clip /	Description	Guidelines for sling sizes		
	<p>Nylon material. Arm rest and back part with anti-slip coating, with safety belts for the belly part and additional padded chest strap. Sling attachment point with clip Washable to 60°C.</p>	Size	Weight	Colour
		S	40 – 60 kg	Red
		M	55 – 85 kg	Yellow
		L	75 – 125 kg	Green
		XL	120 – 160 kg	Blue
	XXL	150 - 205 kg	Orange	

Spare parts or consumables are available upon request from your BEKA Hospitec dealer or directly from the manufacturer.

Sizing/Colors NORA loop style slings (only Kanada / USA)



Size S (red straps, blue rim)



Size M (yellow straps, blue rim)



Size L (green straps, blue rim)



Size XL (blue straps, blue rim)

Please note:

You cannot exchange and replace all spare parts by yourself.

The assembly requires the knowhow of a qualified expert.

13.6 Mounting instructions

13.6.1 Replacing the battery

WARNING



Danger of explosion if battery is incorrectly replaced. Replace only with the same or equivalent type.

Image 1:
The image shows the inserted battery.



Image 2:
Unlock the battery by means of the release lever in the battery handle.



Image 3:
Pull the battery towards the front to remove it.



Image 4:
The image shows the removed battery. When replacing the battery, please check that the release lever engages audibly.



13.6.2 Replacing the hand control

Image 1:
Additional material:
1 hand control



Image 2:
Open the connection flap by releasing the two securing hooks on the side, e.g. with a slotted screwdriver.



Image 3:
Remove the plug of the hand control from the control box (right plug).



Image 4:
Now you can remove the hand control and replace it with a new one. **Pay attention to the coding groove when inserting the plug!**



13.6.3 Replacing the control unit with holder for the battery unit

Image 1:
Required tools:

- 1 slotted screwdriver
- 1 cross-head-screwdriver (PH1)



Image 2:
Additional parts:
1 control unit incl. 2 screws M4x16



Image 3:
Disconnect the NORA Pro from the power supply by activating the emergency stop button. Remove the battery as described in chapter 13.6.1.



Image 4:
Open the connection flap and disconnect all plug connections from the control unit:
- Hand control
- Lifting motor
- Spreader motor
- Charging plug, if applicable.



Image 5:
The picture shows all removed plug connections.



Image 6:
Loosen and remove the screws with cross-head screwdriver (PH1).



Image 7:
Pull the control unit upwards out of the holder.



Image 8:
The picture shows the back of the removed control unit and the mounting plate on the NORA Pro.



Re-assemble in reversed order!

13.7 Electromagnetic compatibility

Electrical medical equipment is subject to special precautionary measures with regard to EMC and must be installed and operated in accordance with the EMC instructions included in the accompanying documents.

For the devices and systems from BEKA Hospitec GmbH, no special measures must be observed.

Portable and mobile HF-communications equipment can interfere with electrical medical equipment.

Guidance and manufacturer's declaration - electromagnetic immunity (Table 201)		
The product has been designed for use in the hereafter listed ELECTROMAGNETIC ENVIRONMENTS. The customer or the user of the product must ensure that the appliance is used in such environment.		
Emission measurements	Compliance	Electromagnetic environment - guidelines
High-frequency (HF) emissions to CISPR 11	Group 1	The product uses HF radiation exclusively for internal functions. Therefore, the HF radiation of the device is very low and any interference with adjacent electrical equipment is unlikely.
High-frequency (HF) emissions to CISPR 11	Class B	The product is intended for use in any type of facility including living quarters and those that are directly connected to a public mains network that supplies residential buildings and buildings used for domestic purposes.
Harmonics to IEC 61000-3-2	Class A	
Voltage fluctuations/flicker to IEC 61000-3-3	Compliant	

Guidance and manufacturer's declaration - electromagnetic immunity (Table 202)			
The product has been designed for use in the hereafter listed ELECTROMAGNETIC ENVIRONMENTS. The customer or the user of the product must ensure that the appliance is used in such environment.			
Immunity testing	IEC 60601- Test level	Compliance level	Electromagnetic environment guidance
Discharging of static electricity (ESD) to IEC 61000-4-2	± 6kV contact discharge ± 8kV air discharge	± 6kV contact discharge ± 8kV air discharge	The floor must be in wood, concrete or ceramic tiles. In case of floors in synthetic material, the relevant air humidity must be at least 30%.
Rapid transient interference pulses/burst IEC 61000-4-4	± 2 kV for power supply cables ± 1 kV for input/output cables	± 2 kV for power supply cables not applicable to input/output cables	The quality of the supply voltage should match that of a typical business or hospital environment.
Overvoltage IEC 61000-4-5	±1 kV cable against cable ±2 kV cable against ground connection	±1 kV cable against cable ±2 kV cable against ground connection	The quality of the supply voltage should match that of a typical business or hospital environment.
Voltage drops, short interruptions and voltage fluctuations in the power supply input cables IEC 61000-4-11	<5 % U_T (>95 % drop of U_T) for 0.5 period <40 % U_T (>60 % drop of U_T) for 5 periods <70 % U_T (>30 % drop of U_T) for 25 periods <5 % U_T (>95 % drop of U_T) for 5 s	<5 % U_T (>95 % drop of U_T) for 0.5 period <40 % U_T (>60 % drop of U_T) for 5 periods <70 % U_T (>30 % drop of U_T) for 25 periods <5 % U_T (>95 % drop of U_T) for 5s	The quality of the supply voltage should match that of a typical business or hospital environment.
Current frequency (50/60 Hz) Magnetic field IEC 61000-4-8	3 A/m	3 A/m	Power frequency magnetic fields should be at levels characteristic of a typical location in a typical business or hospital environment.
CAUTION U_T is the mains AC voltage before the application of the test level.			

Guidance and manufacturer's declaration - electromagnetic immunity (Table 204)			
The product has been designed for use in the hereafter listed electromagnetic environments. The customer or the user of the product must ensure that it is used in such environment.			
Immunity testing	IEC 60601-Test level	Compliance level	Electromagnetic environment guidance
Conducted HF IEC 61000-4-6	3 Vrms 150 kHz up to 80 MHz	10 Vrms	Portable and mobile HF communications equipment should be used no closer to any part of the product including cables, than the recommended separation distance calculated in accordance with the equation applicable to the frequency of the transmitter.
Radiation HF IEC 61000-4-3	3 V/m 80 MHz up to 2.5 GHz	3 V/m	<p>Recommended separation distance $d=0.35\sqrt{P}$ $d=1.2\sqrt{P}$ 80 MHz up to 800 MHz $d=2.3\sqrt{P}$ 800 MHz up to 2.5 GHz</p> <p>With P as the rated output of the transmitter in Watt (W) in accordance with the manufacturer's specifications and d as the recommended separation distance in meter (m).</p> <p>The field strength of fixed HF-transmitters as determined by an electromagnetic field survey, ^a – should be less than the COMPLIANCE LEVEL in each frequency range. ^b</p> <p>In the vicinity of equipment marked with the following symbol, interference may occur:</p> 
<p>NOTE 1: At 80 MHz and 800 MHz, the higher frequency range applies.</p> <p>NOTE 2: This manual could possibly not apply to all situations. Electromagnetic propagation is affected by absorption and reflection from structures, objects and people.</p> <p>^a The field strength of fixed RF transmitters, such as base stations of mobile phones and land mobile radios, amateur radio stations, AM and FM radios as well as radio and television broadcast media cannot be predicted theoretically with accuracy. To assess the electromagnetic environment due to fixed RF transmitters, an electromagnetic site survey is recommended. If the field strength measured in the environment where the product is to be used, exceeds the applicable HF compliance level, special care should be taken that a normal operation of the product can be guaranteed. In case anomalies are identified, additional measures could be required, such as a different alignment or a change of the location of the product.</p> <p>^b In the frequency range from 150 kHz to 80 MHz, the field strength must be less than 10 V/m.</p>			

Recommended distance between portable and mobile communications equipment and the product (Table 206)

The product is intended for use in an electromagnetic environment with controlled HF interferences. The customer or the user of the product can avoid electromagnetic interference by respecting and observing the minimum distance between portable and mobile HF telecommunication devices (transmitters) and the product depending on the rated output of the communication device as given below.

Rated output of the transmitter W	Separation distance depending on the transmitting frequency in m		
	150 kHz to 800 MHz $d=0.35\sqrt{P}$	80 MHz to 800 MHz $d=1.2\sqrt{P}$	800 MHz to 2.5 GHz $d=2.3\sqrt{P}$
0.01	0.04	0.12	0.23
0.1	0.11	0.38	0.73
1	0.35	1.2	2.3
10	1.1	3.8	7.3
100	3.5	12	23

For transmitters rated at a maximum output power not listed above, the recommended separation distance d in meters (m) can be determined using the equation applicable to the frequency of the transmitter, where P is the maximum output power rating of the transmitter in watts (W) according to the specifications given by the transmitter manufacturer.

NOTE 1: At 80 MHz and 800 MHz, the separation distance for the higher frequency range applies.

NOTE 2: These guidelines could not apply to all situations. Electromagnetic propagation is affected by absorption and reflection from structures, objects and people.

13.8 Journal

According to the “Medizinprodukte-Betreiberverordnung” (German Medical Devices Operator Ordinance), you are compelled to keep a journal for this device. Observe your applicable national / local legislation. You can use this journal as template.

Journal

Device: Sit-to-stand lift **NORA Pro**

Manufacturer: BEKA Hospitec GmbH, Am Rübenmorgen 3, 35582 Wetzlar

Serial number: _____

Date of purchase: _____

Site: _____

Checks and inspection conducted upon the first use:

Date: _____

Evidence of the training session on the functions and the use of the product

Instructor		Trained person	
Name	Date	Name	Signature

Periodic inspection, repair, DGUV-3, safety check, etc.

