

Astor CTX2

Height Adjustable Changing and Showering Table

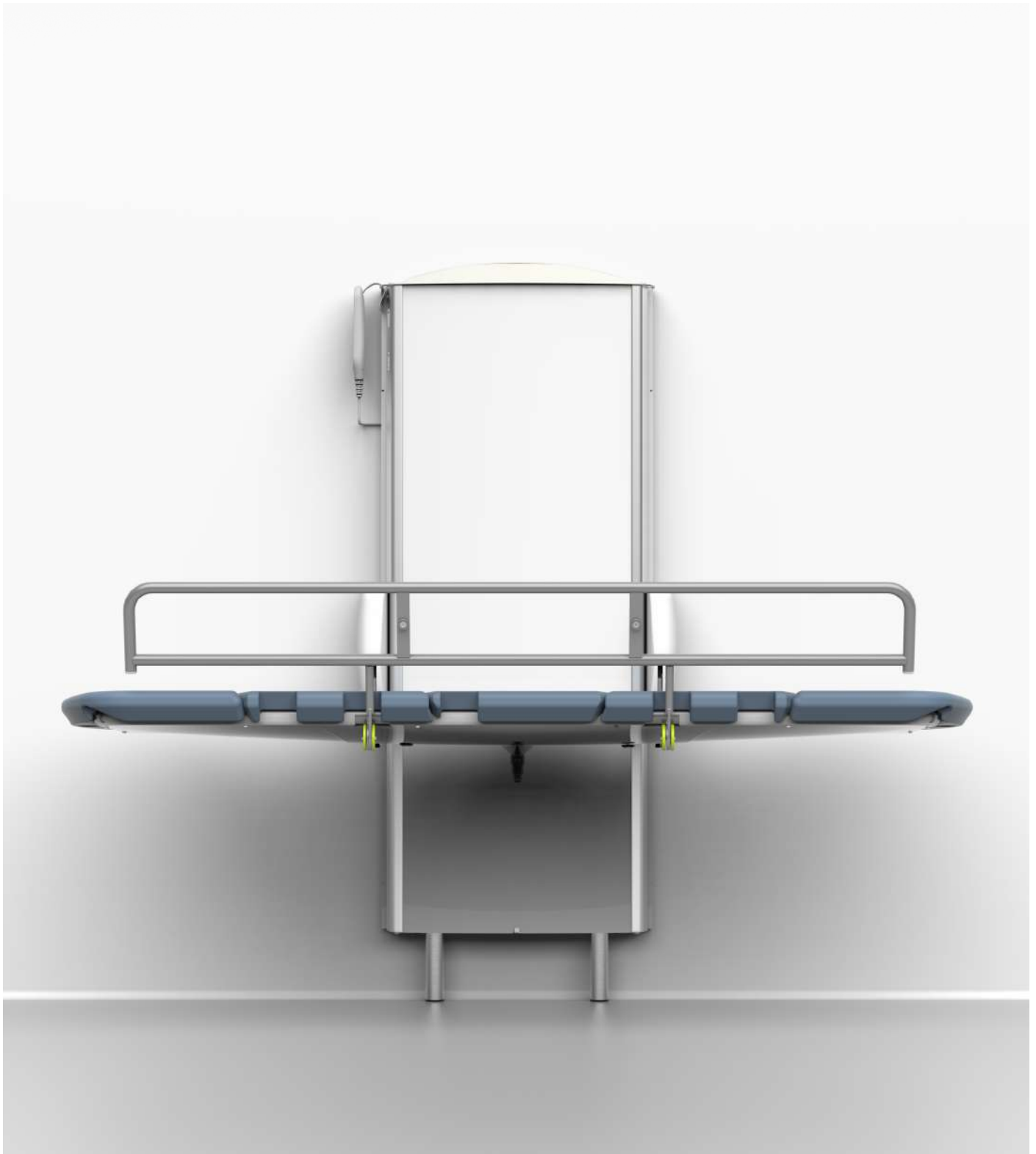

Installation and User Guide



1	Introduction	3
2	Product labels.....	4
3	Warranty	6
4	Caution, safety information & checks	7
4.1	Standard symbols	7
4.2	General safety	9
4.3	EMC declaration	10
4.4	Regular checks	11
5	Finding your way round the product	12
6	Quick guide to operation	13
6.1	Daily checks	13
6.2	Preparing for use	13
6.3	How to stow the stretcher	14
6.4	Adjusting the height of the changing table	15
6.5	Using the front guard	16
6.6	Optional extra - using the end guards	17
7	Cleaning & care	18
8	Troubleshooting	19
9	Technical specification	20
10	Overall dimensions	21
11	Pre-installation	22
11.1	Fixing requirement	23
11.2	Fitting the switched, waterproof flex outlet	24
11.3	Finish the pre-installation & checks	25
12	Installation	26
12.1	Connecting the battery	27
12.2	Connecting the power outlet	28
12.3	Attaching the standard build unit to the wall	29
12.4	Fit the front cover	31
12.5	Fit the light	32
12.6	Fit the stretcher	33
12.7	Option extra - fit the end guards	35
12.8	Fit the gas spring covers	37
12.9	Testing	38
13	Moving & transporting the equipment	39
14	Product disposal	39
15	Replaceable parts	39
16	Service record	40
17	Training record	41

1 Introduction

The Astor CTX2 height adjustable changing table is the ultimate wall mounted showering and changing table offering features to give an enhanced changing and showering experience with ensured comfort and safety. It incorporates a shower tray to ensure waste water from showering is easily managed. Front and end guards are available along with a bumper for the front guard, and a wall cushion for added padding if required.

Intended use

No formal training is required to use the CTX2, but users must read and understand the user guide. To aid usage, a quick user guide should be clearly displayed on the wall at all installations.



CAUTION: The product must not be used for any purpose that is not specified within these operating instructions.

The product is intended to be used by people trained or experienced in healthcare for a family member or client that:

- needs to be changed or cleaned in a lying position
- is older and/or larger than a child able to use a standard baby changing facility
- is likely to require a hoist to transfer to the changing table

Other than the weight of the patient using the changing table, there are no known contraindications associated with this device.

The maximum working load for the CTX2 is 441 lbs (200 kg). The recommended position for use of this equipment is shown in Fig 1.

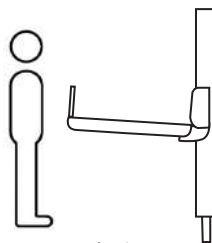

Fig 1

Operating environment

The CTX2 is designed for use in private homes. However, it could be used in any indoor facility at room temperature.

2 Product labels

The labels shown below are labels that will be placed on your CTX2.

An explanation of all symbols found on our products can be found in Section 4.



Fig 2a Product label

The reference number shown identifies the model of your product.

For the variants of the CTX2 see page 5.

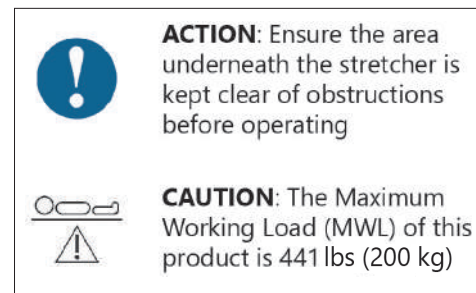

Fig 2b Front cover label

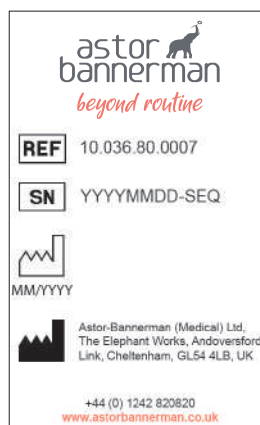

Fig 2c Handset label

CTX2 variants

Reference No	Product
00.036.00.1521	CTX2 Changing Table, Height Adjustable, 1500mm, Front Guard
00.036.00.1525	CTX2 Changing Table, Height Adjustable, 1500mm, Front Guard, LH End Guard
00.036.00.1526	CTX2 Changing Table, Height Adjustable, 1500mm, Front Guard, RH End Guard
00.036.00.1527	CTX2 Changing Table, Height Adjustable, 1500mm, Front Guard, RH End Guard, LH End Guard
00.036.00.1823	CTX2 Changing Table, Height Adjustable, 1800mm, Front Guard
00.036.00.1824	CTX2 Changing Table, Height Adjustable, 1800mm, Front Guard, LH End Guard
00.036.00.1825	CTX2 Changing Table, Height Adjustable, 1800mm, Front Guard, RH End Guard
00.036.00.1827	CTX2 Changing Table, Height Adjustable, 1800mm, Front Guard, RH End Guard, LH End Guard

3 Warranty

Once registered, this product has a 3 year warranty against all defects in manufacture of the product. This does not affect your statutory rights.

To **validate your warranty** and for full terms and conditions, please register your product and your details immediately:

online at: www.astorbannerman.co.uk/services

email our support team: support@astorbannerman.co.uk

or call us on: +44 (0)1242 820820

This warranty is provided by Astor Bannerman to the registered customer.

Equipment requiring commissioning must be commissioned by a competent, Astor Bannerman trained technician for this warranty to be valid.

To maintain the warranty, the equipment must be serviced at least on an annual basis by a competent, Astor Bannerman trained technician. Service or repairs undertaken by persons other than competent qualified technicians may invalidate this warranty.

This product has been designed using quality components and tested under standard usage conditions to give a 10 year service life based on regular servicing and average usage patterns and conditions. This does not alter the warranty offered.



4.1 Standard symbols

Below are some common symbols used throughout this document and on the product labelling.



This product is CE-marked and is certified to BS EN 60601-1:2006+A12:2014 Medical electrical Equipment General Requirements for Basic Safety and Essential Performance, and to BS EN 60601-1-2:2015 for EMC. It also complies with Supply of Machinery (Safety) Regulations 2008, Electrical Equipment (Safety) Regulations 2016, BS EN 349:1993+A1:2008 Minimum gaps to avoid crushing parts of the human body, ISO 10535 Hoists for the transfer of disabled persons, ISO 17966 Assistive products for personal hygiene that support users and BS EN 62262. A declaration of conformity can be found on our website.



This product is UKCA Marked and is certified to BS EN 60601-1:2006+A12:2014 Medical electrical Equipment General Requirements for Basic Safety and Essential Performance, and to BS EN 60601-1-2:2015 for EMC. It also complies with Supply of Machinery (Safety) Regulations 2008, Electrical Equipment (Safety) Regulations 2016, BS EN 349:1993+A1:2008 Minimum gaps to avoid crushing parts of the human body, ISO 10535 Hoists for the transfer of disabled persons, ISO 17966 Assistive products for personal hygiene that support users and BS EN 62262. A declaration of conformity can be found on our website.



Astor Bannerman product reference number.



Astor Bannerman product serial number.



FOLLOW INSTRUCTIONS FOR USE: Before installing or using this equipment you must read and fully understand these instructions. Failure to comply with these instructions may result in accidents resulting in serious personal injury or the product being damaged.



CAUTION: To indicate that caution is necessary when operating the device or control close to where the symbol is placed, or to indicate that the current situation needs operator awareness or operator action in order to avoid undesirable consequences.



WARNING: This symbol indicates a hazardous situation which could result in serious injury or even death if not avoided.



WARNING: This symbol indicated a hazard relating to electricity/voltage.



Type B applied parts. Parts of this product in normal use necessarily comes into physical contact with the patient to perform its function. The product complies with requirements of IEC 60601-1 to provide protection against electric shock. **The applied part for this equipment is the changing table stretcher.**



This product has a duty cycle of 2 minutes ON and 18 minutes OFF.



This product is for indoor use only.



ACTION: Highlights a mandatory action that must be followed by the user.



Identify any terminal which is intended for connection to an external conductor for protection against electric shock in case of a fault, or the terminal of a protective earth (ground) electrode.



Used to identify that a component is suitable for direct current only.



To signify a prohibited action.

4.1 Standard symbols (cont.)



Parts of this product can be recycled.



Parts of this product must be separated when being disposed of.

Pb

The battery used in this product contains Lead.



Details of product manufacturer.



Symbol indicated the date of manufacture.

IPX4

This product has been tested for water ingress in accordance with IPX4.

IK10

This product has been tested for external mechanical impacts in accordance with IK10.



The maximum working load for this product is 441 lbs (200 kg).



The lifting range of this product is 12" (300 mm) to 41" (1040 mm).



WARNING: This symbol indicates a hazard associated with EMC (Electromagnetic Compatibility).



Power supply is equipped with safety isolation and short-circuit protection.



Astor Bannerman products are proudly made in Britain.



Control button to raise the stretcher.



Control button to lower the stretcher.

4.2 General safety information

Further warnings and cautions may be specified in the relevant chapters throughout this document.



WARNING: These instructions must be read and understood before installing or using this equipment. Failure to comply with these instructions may result in accidents resulting in serious personal injury or the product being damaged.

WARNING: No modification of this equipment is allowed without express authorisation from Astor Bannerman. If you suspect that any individual parts may be damaged contact your Astor Bannerman dealer or service provider. Do not remove, attempt to repair or install parts yourself unless directed to do so by Astor Bannerman or its agents.



CAUTION: The product must be installed professionally by a qualified or Astor Bannerman trained individual. Astor Bannerman cannot be held liable for injury to persons or damage to property caused by faulty installation.



WARNING: This electrical equipment conforms to IEC60601-1-2, and needs special precautions regarding electromagnetic compatibility (EMC) and needs to be installed and put into service in accordance with the EMC information. It is unlikely that the user will encounter problems with the product because of inadequate electromagnetic compatibility. However, portable and mobile RF communications equipment can affect medical electrical equipment. When the product is connected to the local mains power supply, we recommend the use of electromagnetic shielding and similar preventative measures to avoid conducted emissions. Prior to installation please ensure that there are no existing equipment in the environment that could be adversely affected by electromagnetic interference. Use of the device should be discontinued if it is suspected that the equipment is being affected by electromagnetic interference.

WARNING: Risk of electric shock if equipment is not used correctly.

WARNING: To avoid the risk of electric shock, this equipment must only be connected to a mains electrical supply with protective earth. The installer must verify that the protective earth terminal of the control box is connected to the external protective earthing system.



WARNING: The product must be connected to the mains supply and a protective earth connection by a qualified electrician in accordance with IEC 60601-1, as well as any locally applicable standards.

WARNING: To ensure protection by electrical separation, the product must be supplied with a mains supply circuit that does not supply power to any other equipment, unless it incorporates a residual current protective device (RCD) with a rated residual operating current not exceeding 30mA. The circuit must be grounded using a protective earth connection and able to be isolated from mains supply by means of a switch installed in a wall or cabinet. Ensure that location of the mains isolation switch or coupling is easy to access and use.

WARNING: The height adjustable changing table is powered by a 32VDC control system with battery backup. The battery enables the use of the changing table in the event of mains electrical supply failure. It is essential that mains electrical power is switched on at all times to maintain the charge of the backup batteries. Ensure that the device is connected to the internal battery at all times.

4.3 EMC declaration

<p>The CTX2 changing table has been tested for compliance to EN 60601-1-2:2015 and is intended for use in the electromagnetic environments specified below. The responsible organisation should assure that it is used in such an environment.</p>			
Guidance and Manufacturer's Declaration - RF Emissions			
Test	Compliance Standard	Electromagnetic Environment - Guidance	
Radiated Emissions Conducted Emissions	CISPR 11:2015 +A1:2016 Group 1, Class A	The CTX2 changing table is suitable for use in a home environment. Its RF emissions are low and are not likely to cause any interference in nearby electronic equipment.	
Mains Harmonics	EN 61000-3-2:2014 Class A		
Mains Voltage Flicker	EN 61000-3-3:2013		
Guidance and Manufacturer's Declaration - Electromagnetic Immunity			
Immunity Test	Compliance Standard	Compliance Level	Electromagnetic Environment - Guidance
Electrostatic Discharge	EN 61000-4-2:2009	± 8kV contact ± 15kV air	Floors should be wood, concrete or ceramic tile. If floors are covered with non-conductive synthetic material the relative humidity should be at least 30%.
Magnetic Field Immunity	EN61000-4-8:2010	30A/m	Mains power quality should be that of a typical commercial environment. If problems are encountered then use of the equipment should be discontinued until the source of interference is identified and corrected.
Radiated RF Immunity	EN61000-4-3:2006 +A1:2008 + A2:2010	3V/metre (28V/m spot frequencies)	
Conducted Immunity	EN 61000-4-6:2014	3V rms (6V in ISM Bands)	
Fast Transient Burst	EN 61000-4-4:2012	±2kV for power supply lines; ±1kV for input / output lines	
Surge Immunity	EN 61000-4-5:2014	±1kV differential mode; ±2kV common mode	
Voltage Dips and Interruptions	EN 61000-4-11:2011 +A1:2017	-100% ½ cycle -100% full cycle -30% 500mS -100% 5000mS	The CTX2 changing table is equipped with a battery backup to permit continued use in the event of a power failure.

4.4 Regular checks

Please note that the cover must be removed to complete servicing tasks (this includes all annual tasks) which must only be done by a qualified person.



DO NOT carry out these checks or service this changing table when a person is lying on the stretcher.

Tasks to be completed:	Start-up	Monthly	Every 6 months	Annually
Disinfect unit	✓			
Clean stretcher	✓			
Check stretcher is undamaged	✓			
Check stretcher is secure with no play (check it does not wobble side to side)	✓			
Check mains power & battery status indicator lights are both green	✓			
Check all pads are in place and not damaged	✓			
Check and disinfect drain using a cleaning disinfectant	✓			
Rise and fall: full function test of the equipment; smooth; no unusual noise		✓		
Check guard(s) locks securely / unlock smoothly		✓		
Check guard(s) rotates freely once unlocked		✓		
Corrosion: inspect the unit for any signs of corrosion		✓		
Cables: Check that all cables from the power supply/control unit are securely fitted and show no sign of damage		✓		
Fixings: Inspect all visible nuts, bolts etc. to see that they are secure		✓		
Check the stretcher angle has not changed when the stretcher is deployed. Stretcher should not be leaning towards the floor. If so arrange a service.		✓		
LOLER test* (to be completed by service engineer)			✓	
Service** (to be completed by service engineer)				✓

*LOLER testing applicable to products used within the UK. Please follow all applicable local regulations.

**To maintain your warranty, and for your safety, this product should be fully serviced annually by a competent, Astor Bannerman trained technician.

Astor Bannerman will make available on request circuit diagrams, component part lists, descriptions, calibration instructions, or other information that will assist service personnel to repair those parts of the equipment that are designated by the manufacturer as repairable by competent service personnel.

If the equipment is likely to not be used for over 1 month then the battery should be disconnected. This can be done by following the reverse of section 12.2.

For further information on servicing offered by Astor Bannerman, contact: service@astorbannerman.co.uk

5 Finding your way round the product

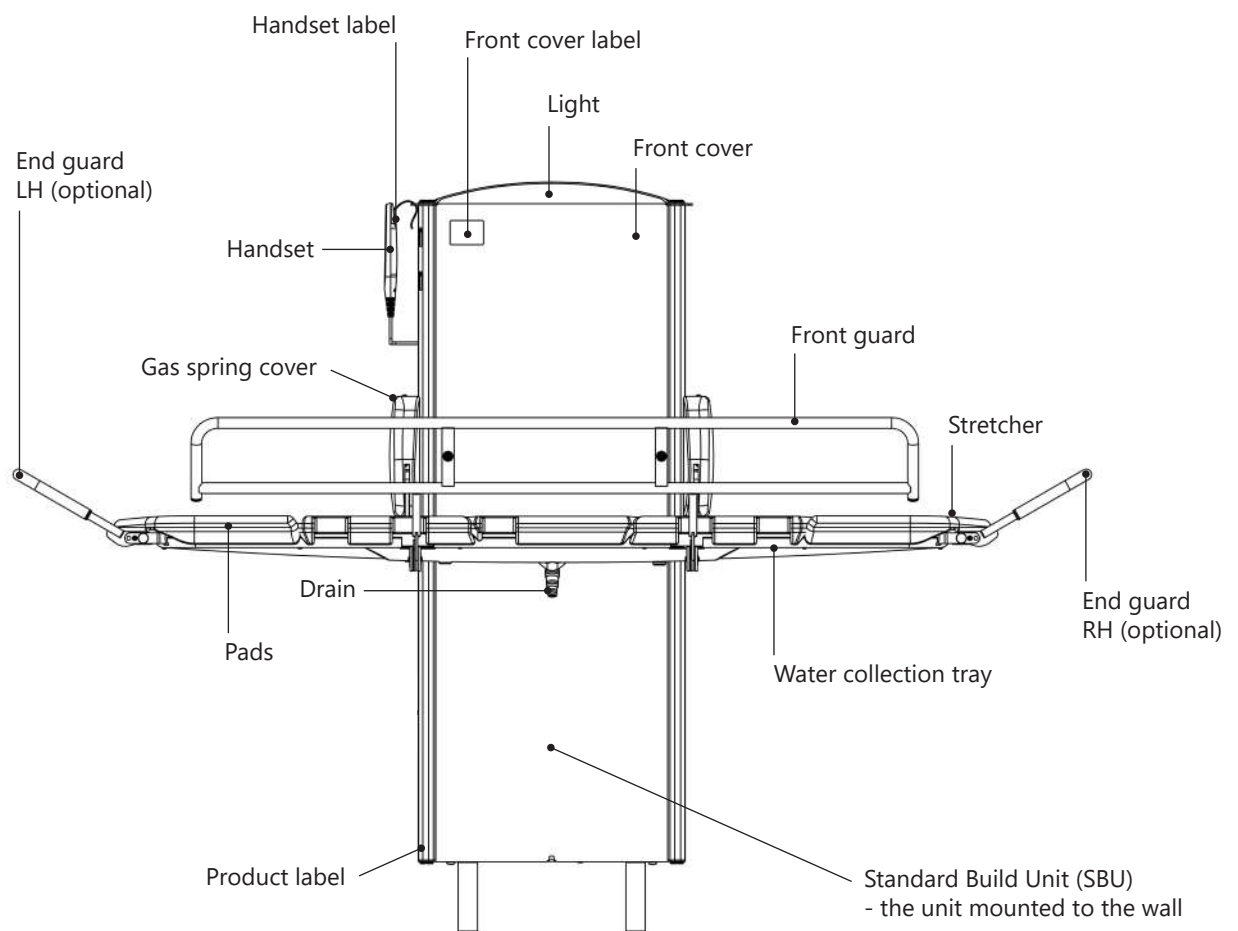

Fig 5

6.1 Daily checks

Carry out the following checks daily before using the changing table:

- Check the weight of the user and ensure the equipment is rated for the weight to be lifted.
- Check the mains electrical supply is connected and turned on. If mains supply is not turned on inform your facility manager.
- Check there are no obstructions or items that may be trapped when the changing table is operated.
- Check that the changing table will raise and lower using the buttons on the handset (see Section 6.4).
- In the event of an emergency where the mains power needs disconnecting, your device should have a mains isolation switch installed separately. (see Section 11 pre-installation requirements)

6.2 Preparing for use

The changing table is securely held in the stowed position by gas springs. There is no release mechanism to operate before deploying the stretcher. To move the bed from the stowed position:

- Place your hand on the top edge of the stretcher.
- Pull gently forward and the stretcher will begin to rotate down.
- During the rotation, the bed will gain a little momentum, so position your hand underneath to aid it lowering slowly down.

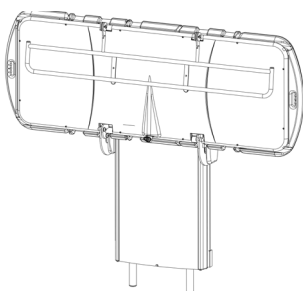

Fig 6.2a

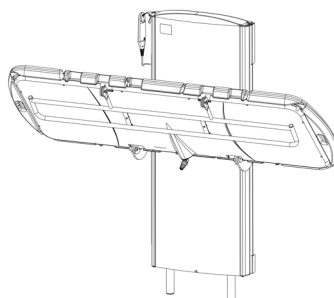

Fig 6.2b

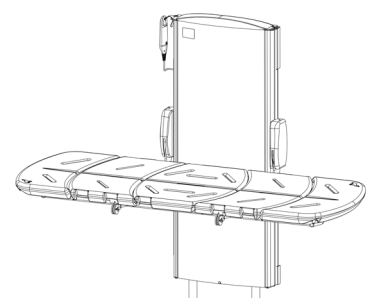

Fig 6.2c



ACTION: Ensure the area underneath the stretcher is kept clear of obstructions before operating.



CAUTION: Keep clear of moving parts when stretcher is being raised or lowered.

6.3 How to stow the stretcher

- Stow the guards as shown in Section 6.5.
- Place your hand on the underside of the stretcher.
- Pull gently upwards and the stretcher will begin to rotate up.
- During the rotation, the bed will gain a little momentum, so position your other hand on the end of the stretcher to control the movement safely.

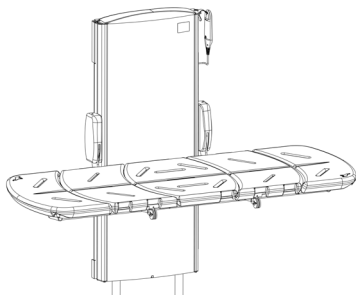

Fig 6.3a

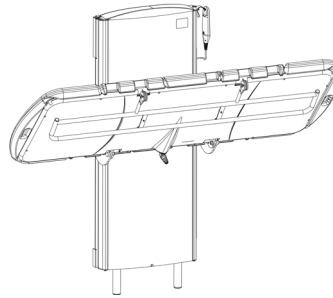

Fig 6.3b

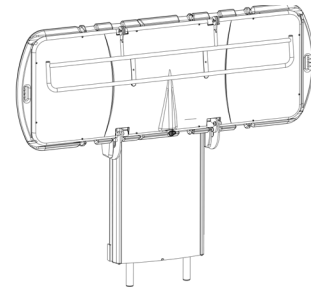

Fig 6.3c



ACTION: Ensure the area around the stretcher is kept clear of obstructions before operating.



CAUTION: Keep clear of moving parts when stretcher is being raised or lowered.

6.4 Adjusting the height of your changing table

- The changing table is operated using the handset. (Fig 6.4a/b)
- The handset buttons will raise or lower the changing table to the desired height.
- The handset button with a light symbol will turn the integrated light on and off.
- Use the raise/lower buttons to position the table at the most convenient height to transfer the person being cared for.
- Once the person has been transferred, raise the guard (see Section 6.5)
- The stretcher height can then be adjusted to suit a height most comfortable for the care-giver.

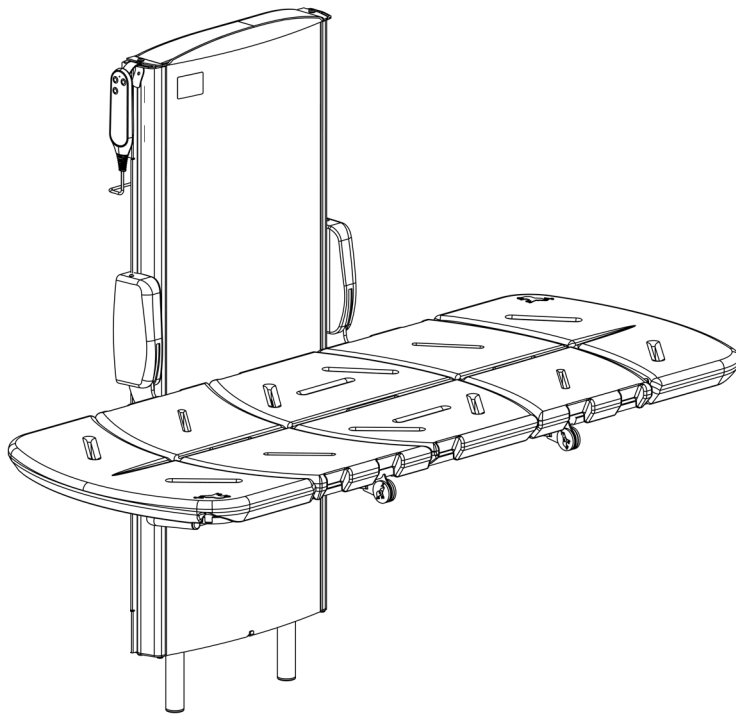

Fig 6.4a



Fig 6.4b

Please note that handset designs may vary.



WARNING: Risk of injury by crushing. Ensure the area underneath the stretcher is kept clear of obstructions before operating. Keep clear of the area above the stretcher when stowing.



CAUTION: Keep clear of moving parts when operating. Ensure there are no obstructions when moving the guards into position.



ACTION: Always deploy the guards before moving the changing table with a person on the stretcher.



ACTION: Ensure the area underneath the stretcher is clear of obstructions before operating.

6.5 Using the front guard

The CTX2 changing table has a front guard and optional end guards.



ACTION: Always deploy the front guard before moving the changing table with a person on the stretcher.

To deploy guard into place:

- Reach underneath the stretcher and take hold of the guard. The guard is retained using magnets. (Fig 6.5a)
- Pull down on the front edge of the guard so it rotates down. Take care not to let go as it may swing around on its own. (Fig 6.5b)
- Rotate the guard forward and up into position.
- Once upright, the guard will be able to drop down into its location and lock into place. (Fig 6.5c)

To stow the guard:

- Lift the guard up until it can be rotated back towards you.
- Rotate the guard down and back underneath the stretcher.
- Push the guard up underneath the stretcher until the magnets retain the guard.



CAUTION: Ensure there are no obstructions while moving the guards into position.

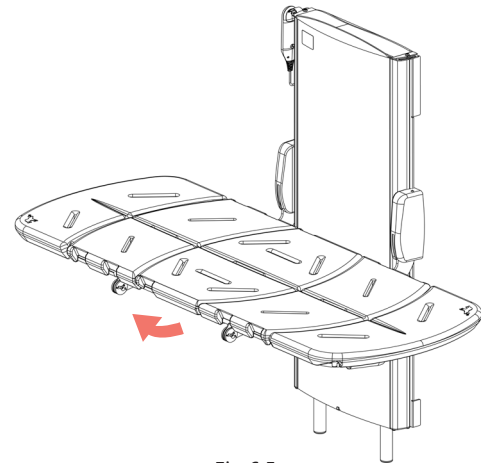

Fig 6.5a

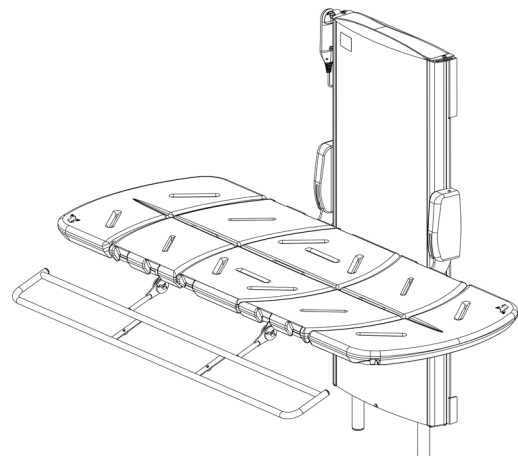

Fig 6.5b

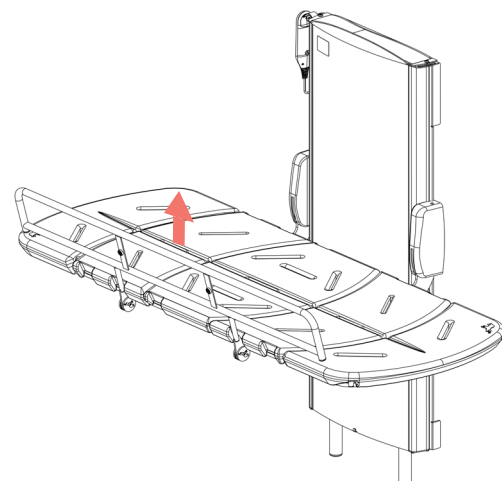

Fig 6.5c

6.6 Optional extra - using the end guards

The CTX2 changing table has optional end guards.

To deploy the end guard into place:

- Pull the black index plunger to release the locking pin.
- Rotate end guard to highest position.
- Ensure the pin locks back in place.

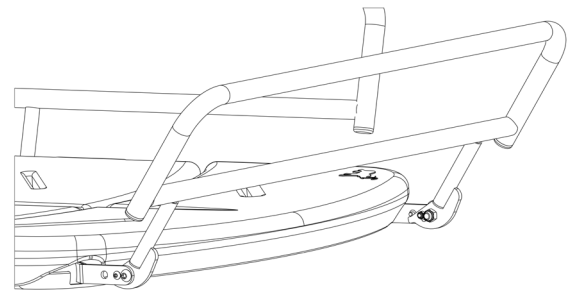

Fig 6.6a

To stow the end guard:

- Pull the black index plunger to release the locking pin.
- Rotate end guard to lowest position.
- Ensure the pin locks back in place.

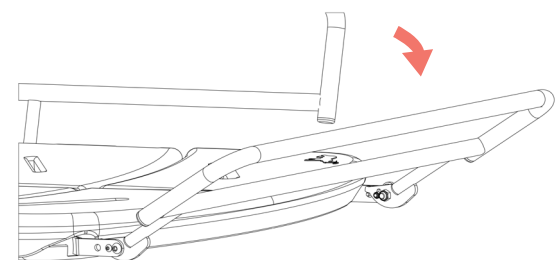

Fig 6.6b



CAUTION: Ensure there are no obstructions while moving the guards into position.

7 Cleaning & care

The Astor CTX2 should be regularly cleaned and must be cleaned between users to prevent the risk of cross contamination of infection.

Cleaning:

- Before cleaning, try a small test first in an inconspicuous area with the cleaning agent you are proposing to use.
- The changing table may be cleaned using mild cleaning agents, Isopropyl alcohol (maximum 70% alcohol) or with a warm soapy water solution. The changing table should be rinsed off after cleaning and dried off with a soft cloth.
- Chemical agents, abrasive compounds and solvents must not be used, i.e. drain cleaners, acetone, oven cleaners or acids.
- Attention should always be paid to instruction labels for the cleaning agent.
- Do not use an autoclave or other type of steam cleaner to clean any part of the product.
- The main unit of the device may be cleaned with the same solution used on the stretcher, a stainless steel cleaner may be used on the front cover to remove any marks.



ACTION: Ensure any cleaning product spillages are cleaned up correctly.



CAUTION: Always follow the instructions and comply with the safe use of the cleaning/disinfecting agent. Do not mix cleaning products.



CAUTION: Do not use flammable cleaning agents.



CAUTION: Do not use abrasive cloths or cleaners.



CAUTION: A dampened, non-wet cloth should be used for cleaning.



CAUTION: Do not pour or spray cleaning liquids directly onto the equipment.

8 Troubleshooting

Problem: The stretcher won't move up or down

Suggestion: Check that the mains power supply is switched on. Check that you are using the correct button for the direction of your choice. If the stretcher still won't move, please contact Astor Bannerman service team on +44 (0)1242 820820 or support@astorbannerman.co.uk

Problem: I cannot release the front guard

Suggestion: The guard is held in place by magnets, so with a strong tug, they should release easily enough.

Problem: I cannot put the front guard down to stow it

Suggestion: The front guard is held in place by an auto-lock mechanism. To release this you need to lift the guard before you try to rotate it down.

Problem: My front guard does not stow correctly

Suggestion: The guard is held in place with magnets fixed to the underside of the stretcher. Ensure you have rotated the guard to meet the underside of the stretcher so that the magnets engage.

Problem: I have an idea for improving my product; some feedback, or there's something that doesn't work as expected

Suggestion: Astor Bannerman are committed to continuous improvement. Please contact our service department with suggestions, improvements, feedback or to let us know of any problems with your product on +44 (0)1242 820820 or support@astorbannerman.co.uk

9 Technical specification

AC input	110VAC-240VAC, 50/60Hz, 382VA
Power supply	Class II power supply
Applied part	Applied part type 'B'
Battery specification	Lead acid battery/ "non-spillable" Input 30V - Output 24V Supplier reference - TiMotion (TBB2-4307-001)
Battery model	TiMotion TBB2 1.2A
Fuses	5Amp fuses (External to the device, part of the mains supply system)
Duty cycle	10% maximum
Maximum working load	441 lbs (200 kg)
Sound emission	L _{Aeq} 56dB at maximum working load
Length	87 13/32" (2220mm) for 70 7/8" (1800 mm) stretcher
Height	60 31/32" (1549 mm)
Depth	35 15/16" (913 mm) - Front guard deployed
Weight of product	98 kg / 216 lbs
Materials	Mild Steel, Stainless Steel, Polyurethane, ABS
Operating ambient temperature range	10°C to 40°C / 50°F to 104°F
Operating relative humidity range	10 - 80% not condensed at 20°C / 68°F
Operating atmospheric pressure	50kPa to 106kPa
IP class	IPX4
Transport & storage conditions	10°C to 40°C / 50°F to 104°F 10 - 80% not condensed at 20°C / 68°F



CAUTION: Battery must only be replaced by qualified service personnel. Replacement battery must be the same model as the original battery supplied with the device.

10 Overall dimensions

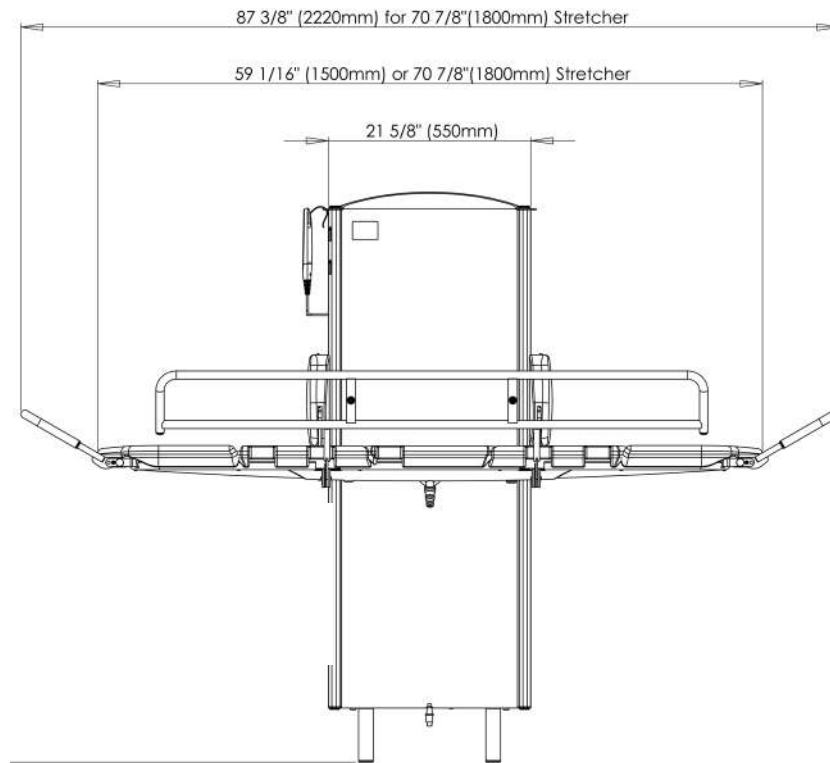

Fig 10a

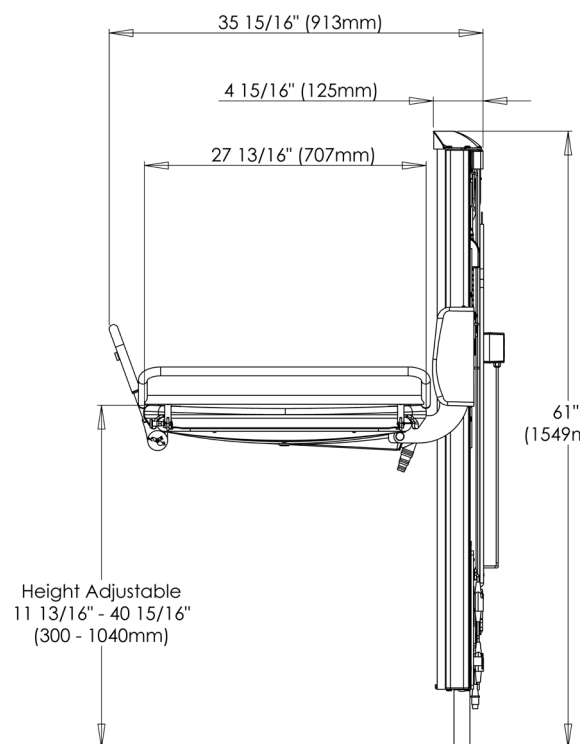

Fig 10b

11 Pre-installation

Before your CTX2 can be installed, the wall and mains electrical supply must have been prepared as set out below. Pre-Installation works should be carried out by a competent and qualified professional in compliance with local and national building code standards.

- Electrical requirement: Ensure electrical hazards are fully understood before commencing pre-installation, see Section 4.2 page 9 for detail. This device is powered by a Class II power supply. A mains supply to suit the technical specification is required through a switched, waterproof, flex outlet. This must be fitted as described below. (See technical specification)
- There must be an easily accessible mains isolation switch fitted for this device. It is recommended to be located in a separate room or in a cabinet. If the mains isolation switch is out of sight the switch should have a lock. To conform to IEC60601 clause 8.11.1 both poles of the electrical supply must be isolated. If the isolator is out of the view of personnel servicing the equipment then it shall be capable of being locked in the off position.
- The CTX2 is a wall-mounted, floor standing product.
- This product must be connected to a suitable mains earth.



WARNING: Ensure the electrical mains supply is isolated from power while connecting the product to the mains supply.

11.1 Fixing requirement



WARNING: Ensure supporting wall and fixings are suitable and correctly installed by a competent and qualified professional. Risk of collapse of equipment if the strength of the supporting wall structure is inadequate.

- A clear 120 1/2" (3060 mm) width area is required for fitting this product. If you do not have end guards fitted this value can be reduced to 92 1/8" (2340 mm).
- The wall must be load bearing and strong enough to support 1100 lbs (500 kg). It must be flat and free from obstructions from floor to ceiling.
- The wall fixings must be load bearing and strong enough to bear a load of 220 lbs (100 kg) on each of the wall fixings.
- If required, the wall construction can be faced with minimum 23 5/8" (600 mm) wide, 1" (25 mm) thick marine plywood which continuously extends from floor to ceiling.
- If the wall is stud and faced with marine plywood it must be from floor to ceiling and secured every 7 7/8" (200 mm) around the perimeter and to at least two supporting horizontal cross members.
- Ensure any horizontal cross members or parts of the wall construction are not located at the same height as the changing table's fittings in order to avoid a future installation problem.
- Astor Bannerman cannot be held responsible for the reinforcements made in a faulty manner.

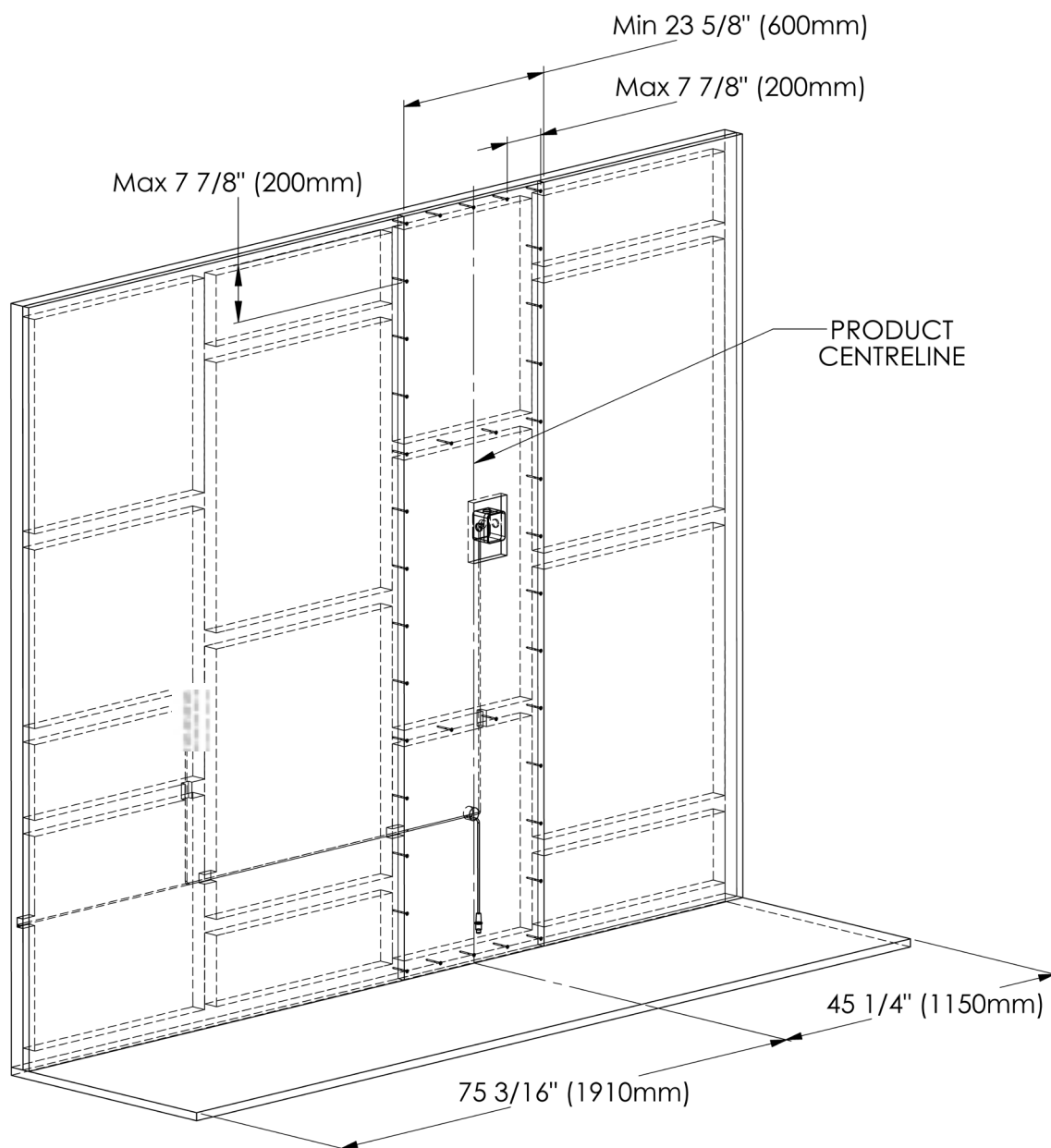

Fig 11.1 Preparing the wall

11.2 Fitting the switched, waterproof, flex outlet

- A switched, waterproof flex outlet is required for hard wiring the product to. This outlet must be located in the position shown in Fig 11.2. The outlet cannot be any larger than 7 1/2" (191mm) tall or 5 5/8" (142 mm) wide and must be flush or sub-flush to the level of the marine plywood once fitted.
- Examples of suitable outlet types are K56410GRY from MK Electronics or WPB50 from British General.

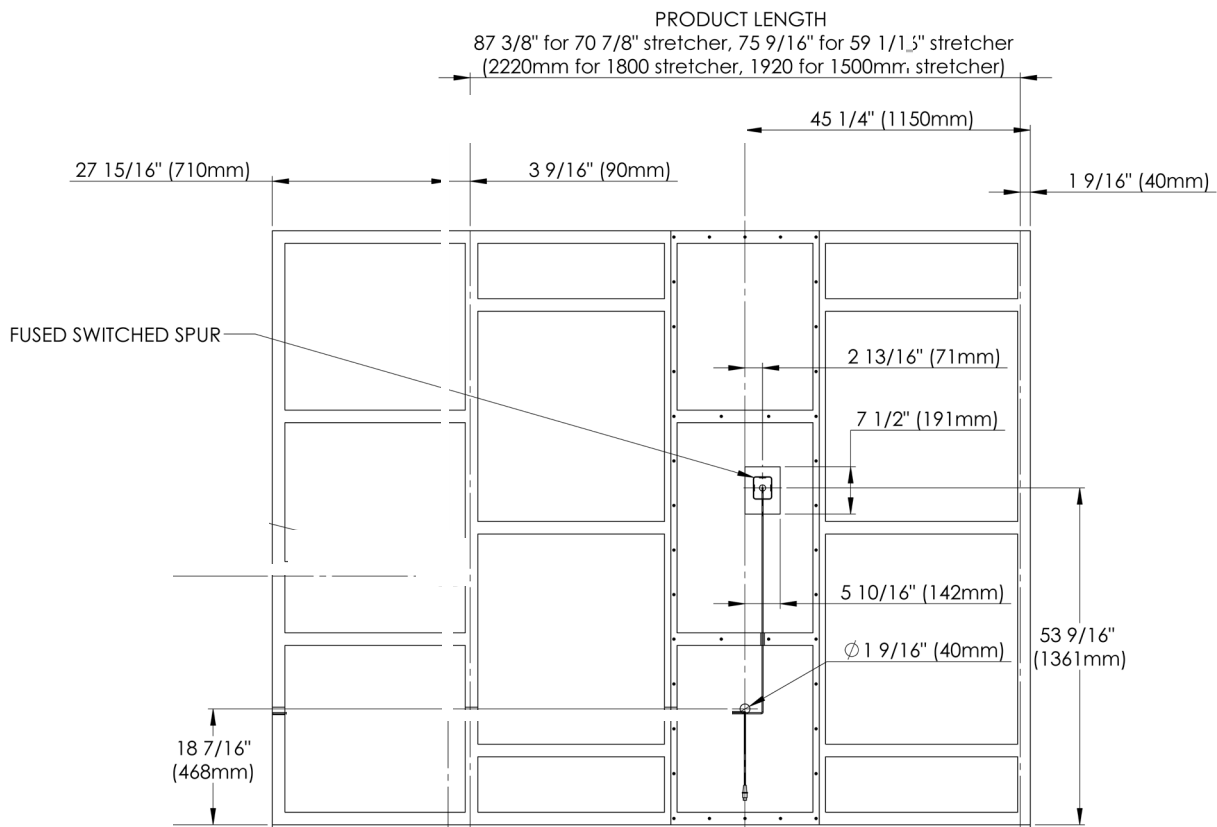

Fig 11.2 Switched waterproof, flex outlet

11.3 Finished pre-installation & checks

- The finished pre-installation should appear like Fig 11.3.
- Drywall/plasterboard is fitted to appear flush with the marine plywood. This wall can then be blended/painted so to appear as a finished wall.

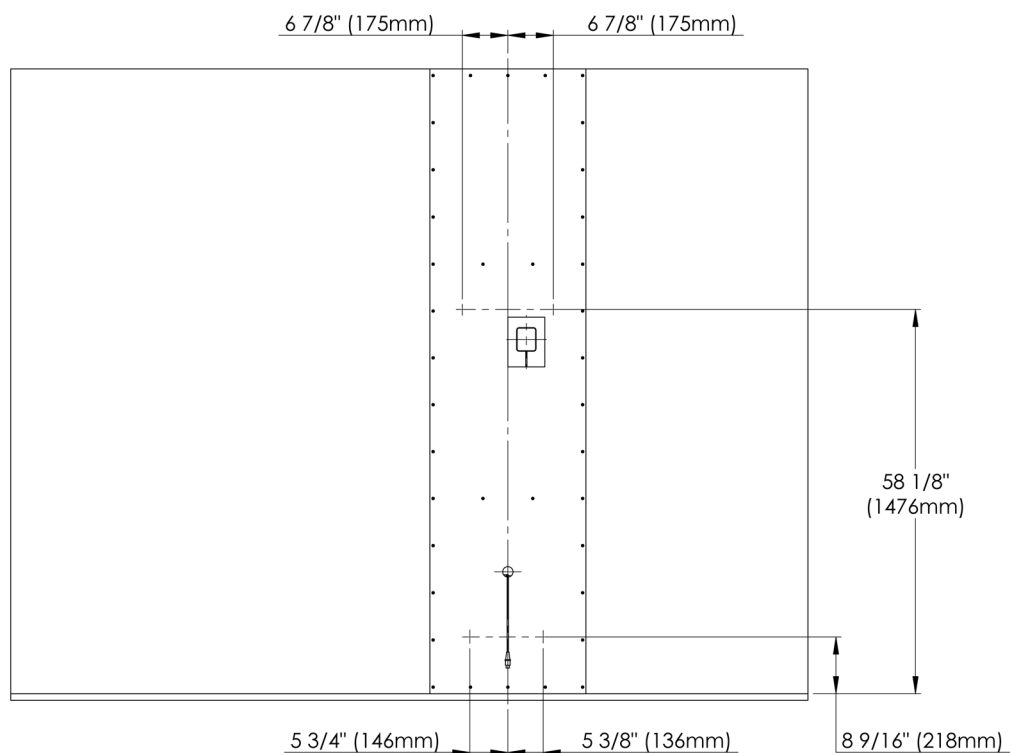

Fig 11.3 Fixing points of SBU

Checks:

- The wall must be load bearing and strong enough to support 1100 lbs (500 kg). It must be flat and free from obstructions from floor to ceiling.
- The switched, waterproof flex outlet has been fitted in the position shown in Fig 11.2, is no larger than the stated dimensions and flush or sub-flush with the wall.

12 Installation

The CTX2 must be installed by a competent and qualified technician in compliance with local and national building code standards.

Ensure that all pre-installation works have been carried out & checked in accordance to Section 11.

Externally accessed security fixings require specific tools which are provided. Please keep them safe after completing installation for future servicing.

12.1 Connecting the battery

The product has been provided without the battery connected.

- Looking at the rear of the product, locate the female connector, as shown in Fig 12.1a.

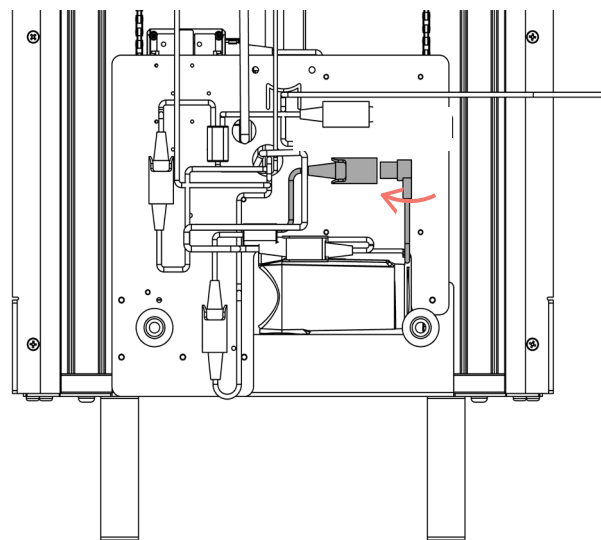

Fig 12.1a

- Make the connection by rotating the female connector clip cover and fully insert the male connector. The female clip cover should then easily rotate back over to secure the connection.

- Tidy the cable behind the product so that it is not visible once the SBU is against the wall. Ensure it does not protrude further than any of the other cables.

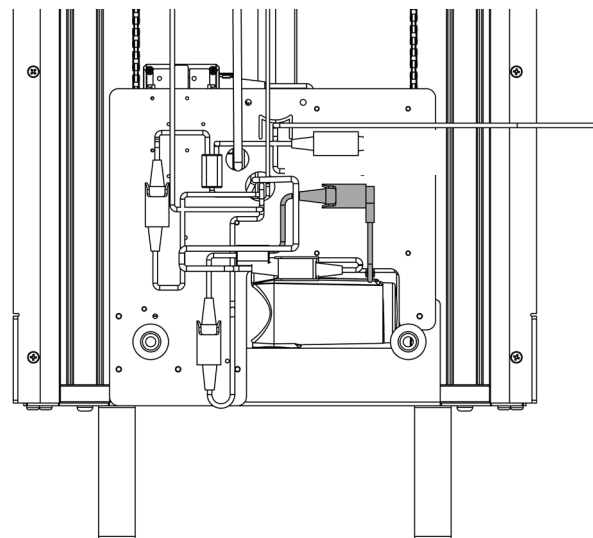

Fig 12.1b

12.2 Connecting the power outlet



WARNING: Ensure the mains electrical supply is isolated from power while connecting the product to the mains electrical supply.

A switched, waterproof flex outlet should have been previously fitted in accordance with Section 11. The outlet cannot be any larger than 7 1/2" (191 mm) tall or 5 5/8" (142 mm) wide and must be flush or sub-flush to the level of the wall.

- Position the SBU against the wall in the approximate mounting position which will allow the mains power cable to reach the outlet.
- Hardwire the product to the outlet in accordance with local and national regulations.
- The mains cable from the unit must be protected from moving parts by trunking. At minimum this should extend from the top of the plastic board which retains the fixed electrical components to the outlet. It should be no deeper than 5/8" (16 mm) from the wall and ideally should be positioned 1 1/2" (40 mm) to 3" (100 mm) from the centreline of the product.

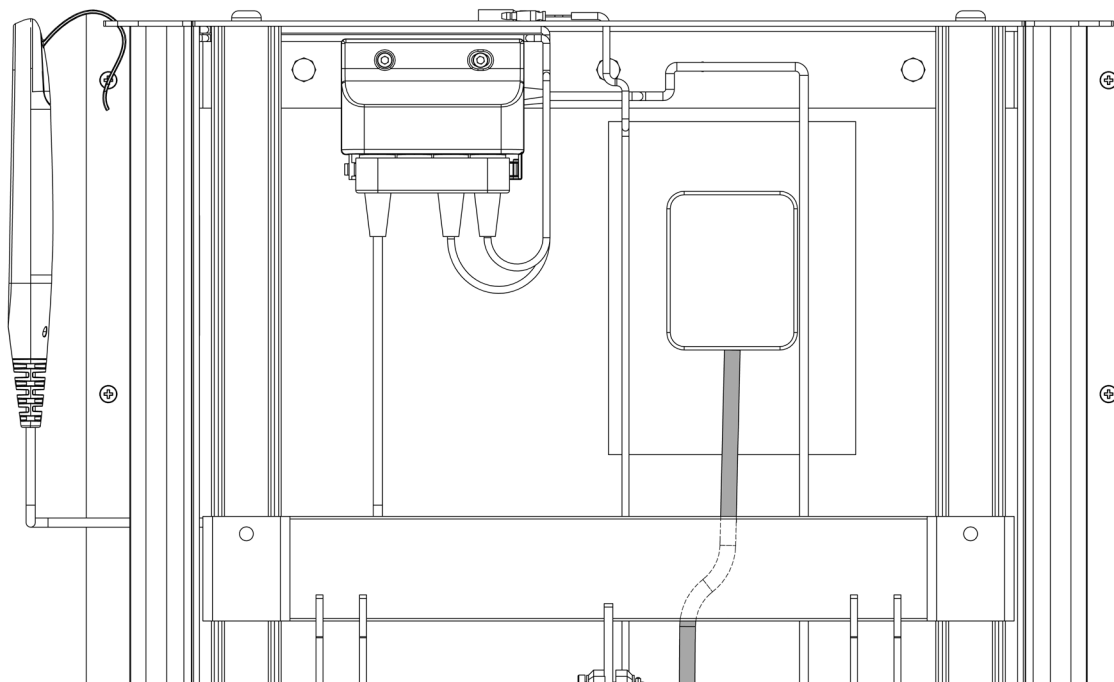

Fig 12.2

12.3 Attaching the standard build unit to the wall

- The wall must have been suitably prepared and reinforced as explained in Section 11 during the pre-installation phase.
- Align the SBU to the wall about the centreline ensuring it is level. If the floor is uneven the feet can be manually adjusted.
- If the floor is uneven, the feet can be adjusted by rotating the black plastic screw head on the bottom of the foot up to 20 mm / 0.8 inches.

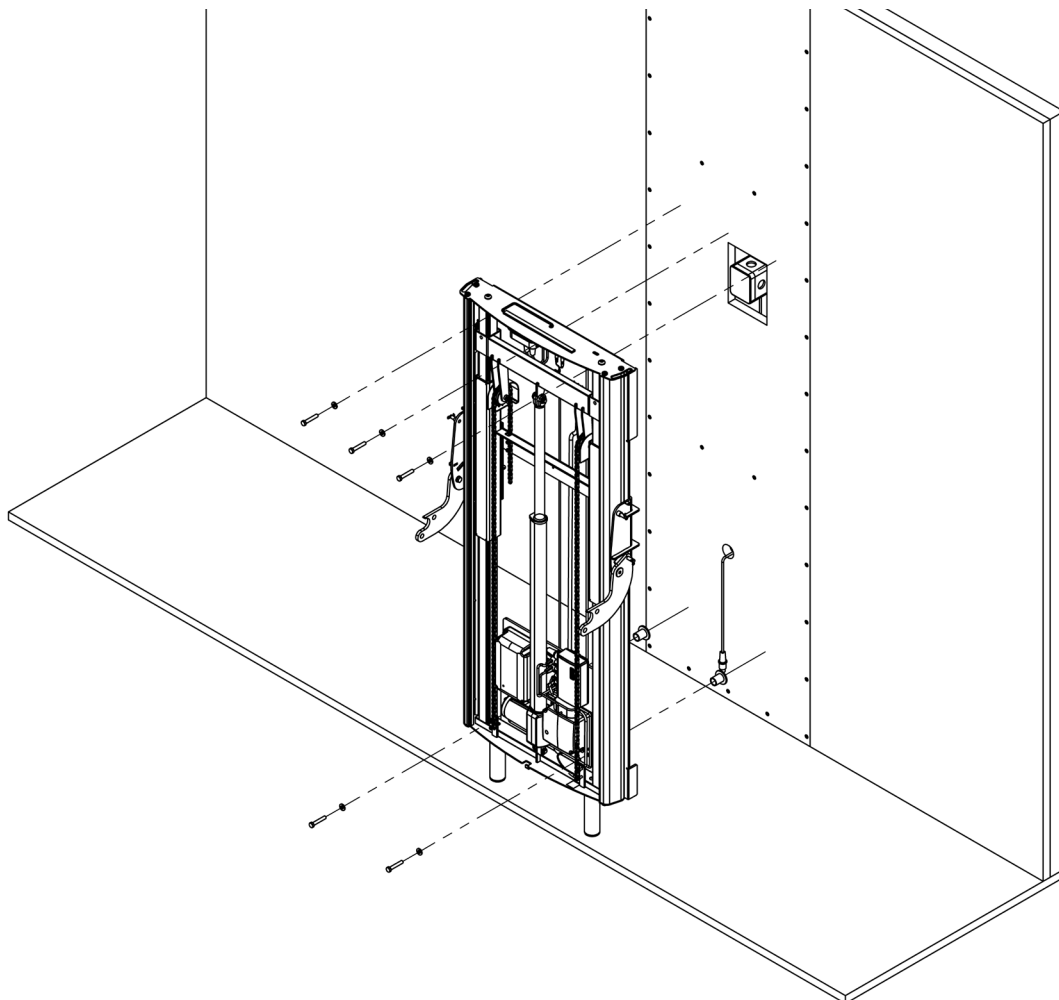

Fig 12.3a

12.3 Attaching the standard build unit to the wall

- With the product in place, mark out the five fixing holes, set the SBU aside and then pilot drill your suitable fixings.
- Using suitable fixings fit the top three first and then lower two. Ensure you have used the provided spacers on the bottom two fixings.

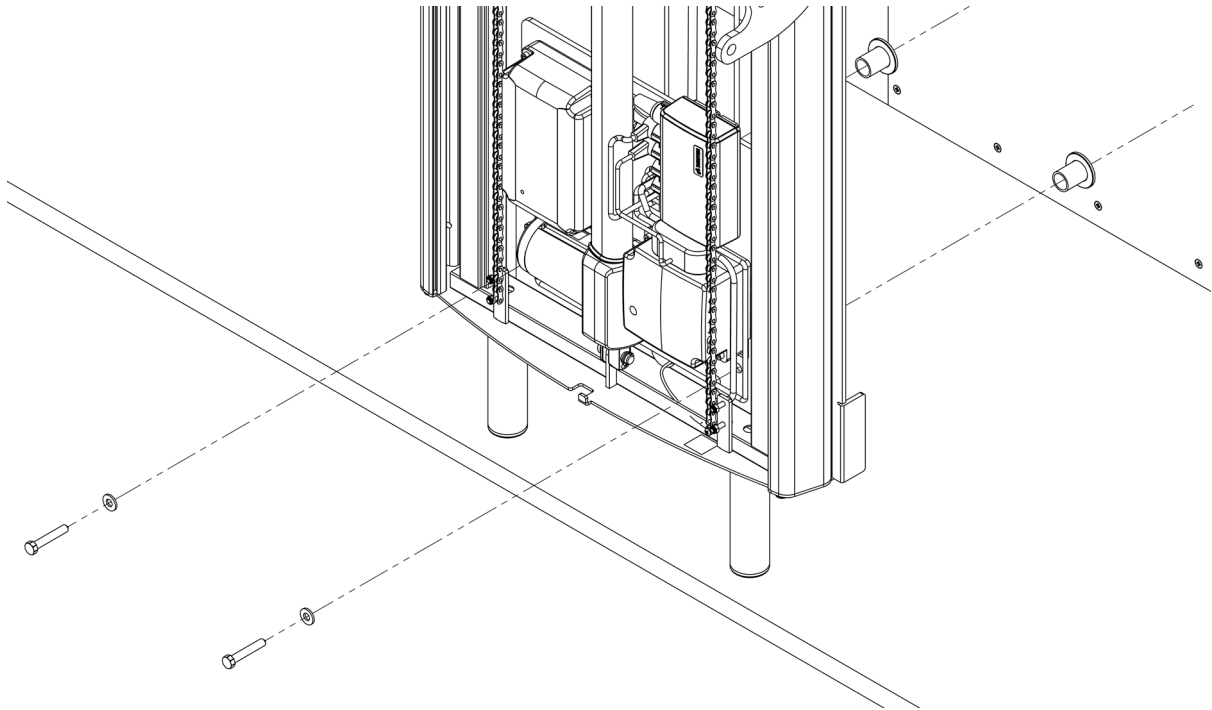

Fig 12.3b

- Tighten all five fixings until they are flush.

12.4 Fit the front cover

The front cover can now be fitted. Care should be taken not to scratch the front cover.

- Pull the light strip connectors through the top of the SBU before fitting the cover (loosely tape to secure).
- Locate the supplied front cover.
- Slot into the left hand side.
- Starting at the bottom centre ensure that the cover is behind the hook on the bottom plate as shown in Fig 12.4b.
- Bend the cover and push the bottom right hand corner into the slot.
- Push vertically upwards along the right hand edge until the cover engages the full length of the slot.
- Once slotted into the right hand side, ease the cover down behind the front retainer on the bottom edge.

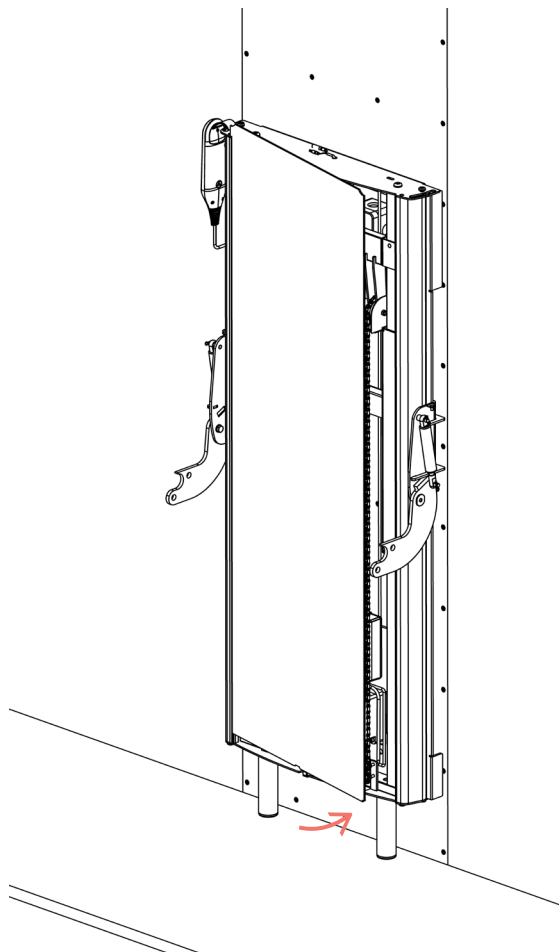

Fig 12.4a

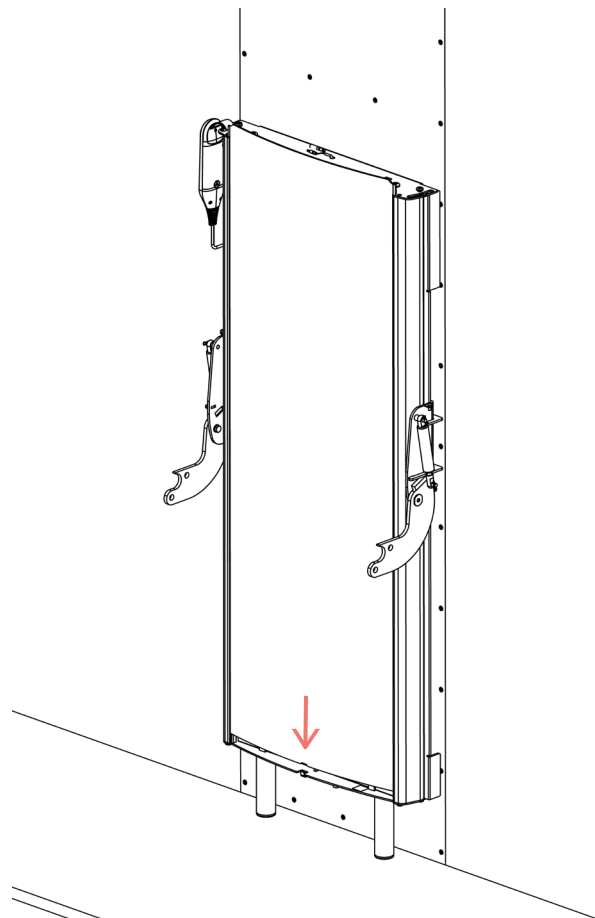

Fig 12.4b

12.5 Fit the light



WARNING: Ensure the electrical mains supply is isolated from power while connecting the light.

The light can now be fitted.

- Remove the two screws from the top of the SBU as shown in Fig 12.5a.
- Connect the LED strip from within the light housing to the SBU.
- Fit the light housing to the top of the SBU using the previously removed screws as shown in Fig 12.5a.

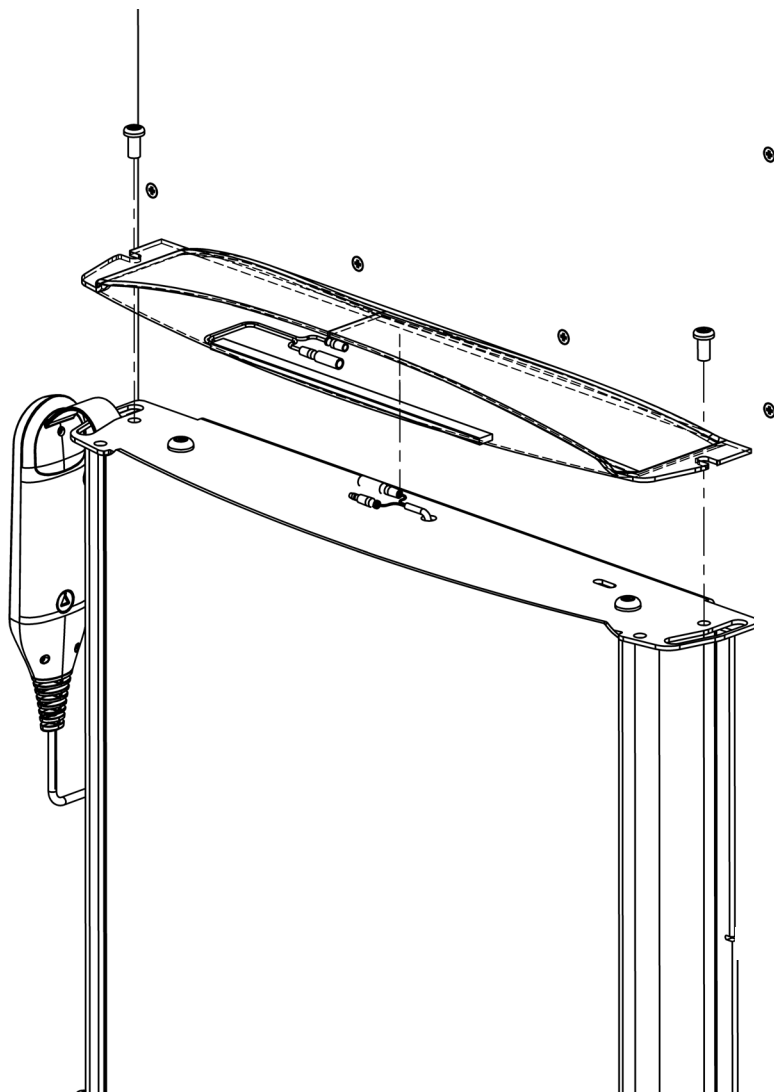

Fig 12.5a

12.6 Fit the stretcher



CAUTION: Take care when fitting the stretcher to the product. This is a heavy item and we recommend two people install the stretcher.

Remove the pads by lifting them vertically as shown in Fig 12.6a to aid with installation.

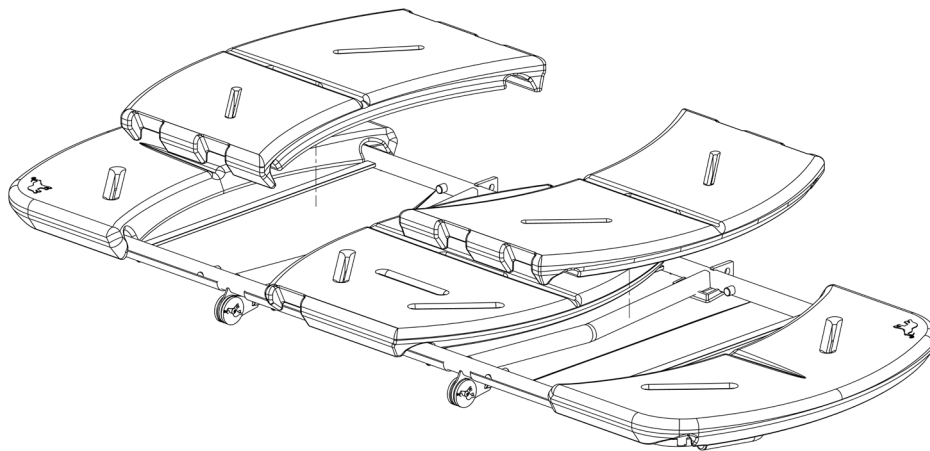

Fig 12.6a

- Bring the stretcher towards the product and rest as shown in Fig 12.6b.

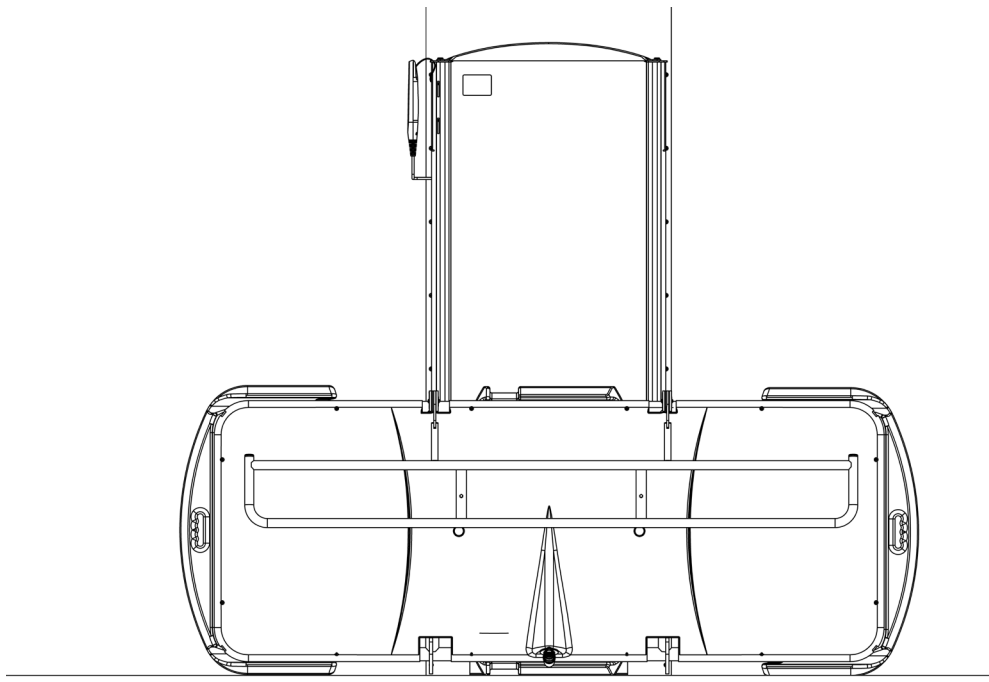

Fig 12.6b

12.6 Fit the stretcher

- With two people, lift the stretcher vertically and slot the SBU arms in the middle of each stretcher brackets, see Fig 12.6c.

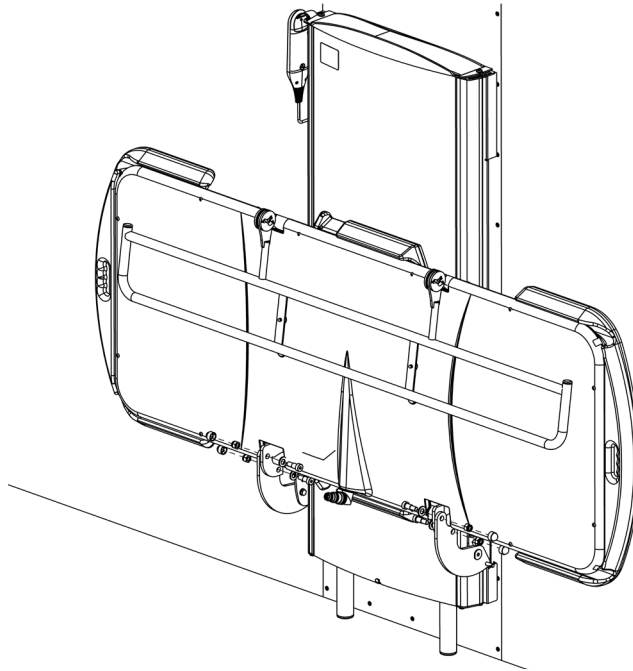

Fig 12.6c

- Once in position secure the provided M10 x 16 mm bolts and M10 nuts provided. Finish by covering the nut with the caps provided as shown in Fig 12.6d.
- Once all the fasteners are secured, fold and stow to check the stretcher is moving freely and without restriction. Refit the pads as shown in Fig 12.6a.

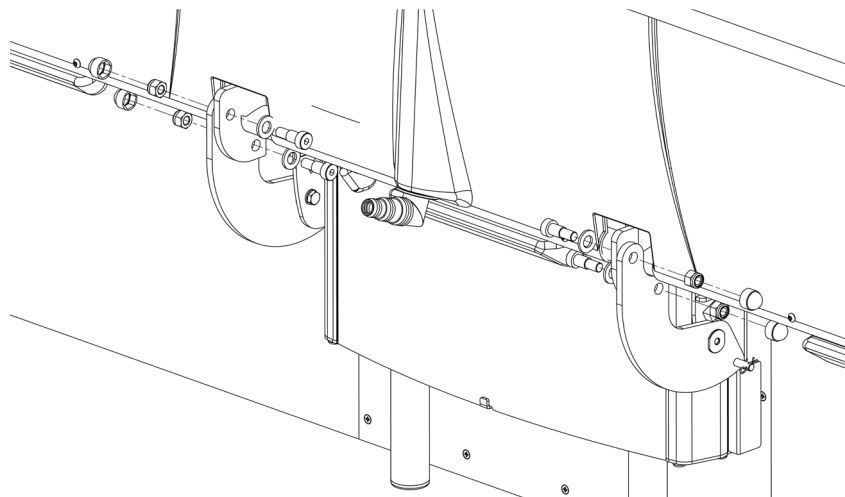

Fig 12.6d

12.7 Optional extra - fit the end guards

End guards are an optional extra which must be specified during your purchase of the CTX2. They cannot be retrofitted. Please continue to the next section if you did not require end guards.

- The end guards should be fitted after the changing table is fully assembled.
- The end pad may be removed to aid access.
- Align the end guard mounting holes to the final two holes on the stretcher mounting bracket.
- M8 x 20 mm with an M8 nut on the outermost fixing hole and M5 x 16 mm with an M5 nut on the centre hole to slot.
- There should be one index plunger for each end guard, and this should be fitted to the front-side of the stretcher for ease of use.
- An M10 nut is fitted to the index plunger. Screw the index plunger assembly into the stretcher bracket.
- The M10 nut can be adjusted until the end of the threaded body sits flush to the inside of the bracket, and just the sprung pin is protruding.

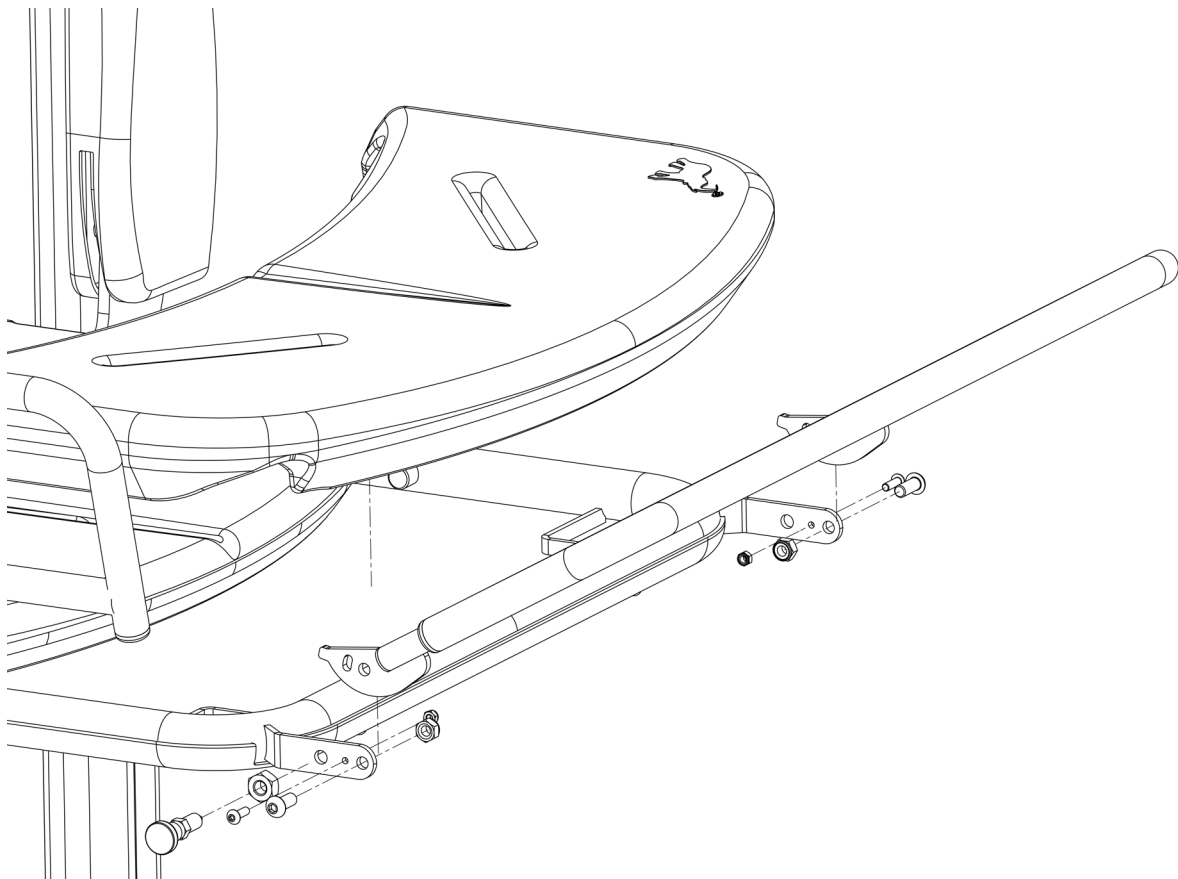

Fig 12.7a

12.7 Optional extra - fit the end guards

- Once the fixings are secure, the index plunger may be pulled to test the two positions available for the end guards. Ensure bolts are not overtightened which could restrict the movement of the guard.
- Repeat this process if end guards have been specified for both ends of the stretcher.

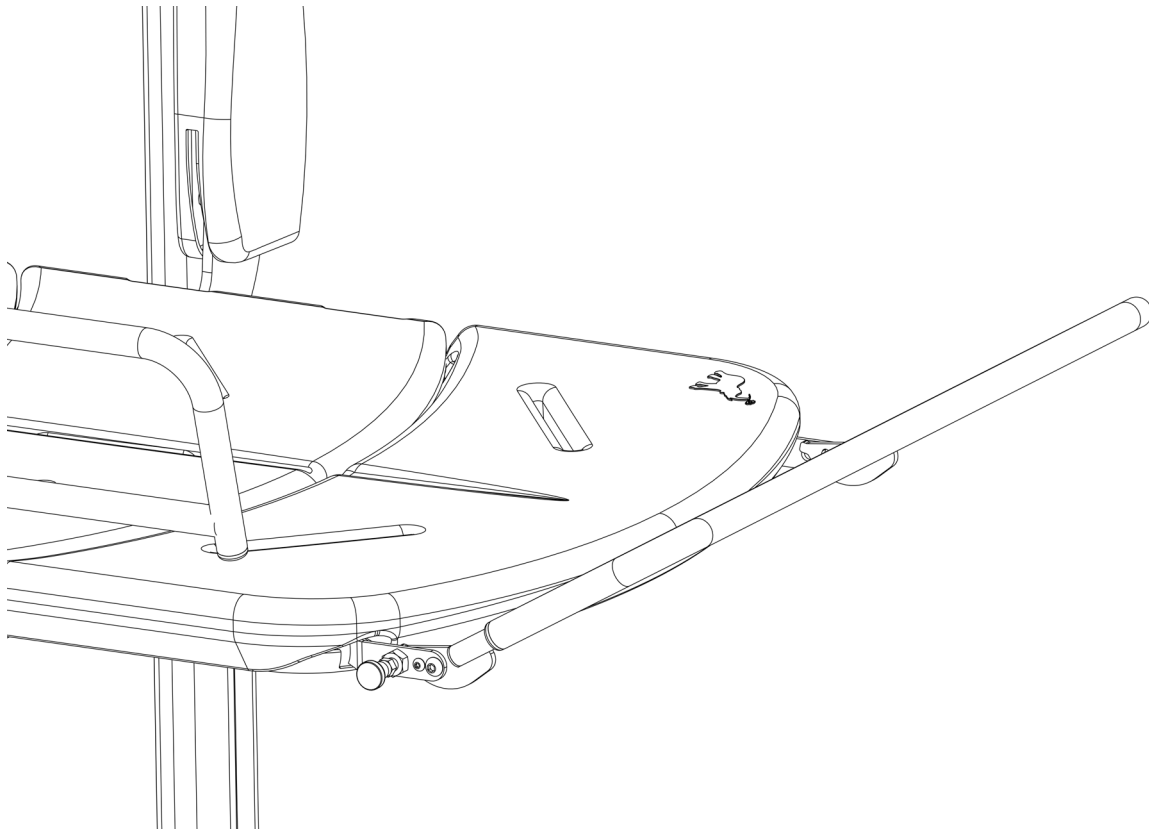

Fig 12.7b

12.8 Fit the gas spring covers

The gas spring covers can now be fitted.

- Locate the gas spring covers and rotate into position, as shown in Fig 12.8a.

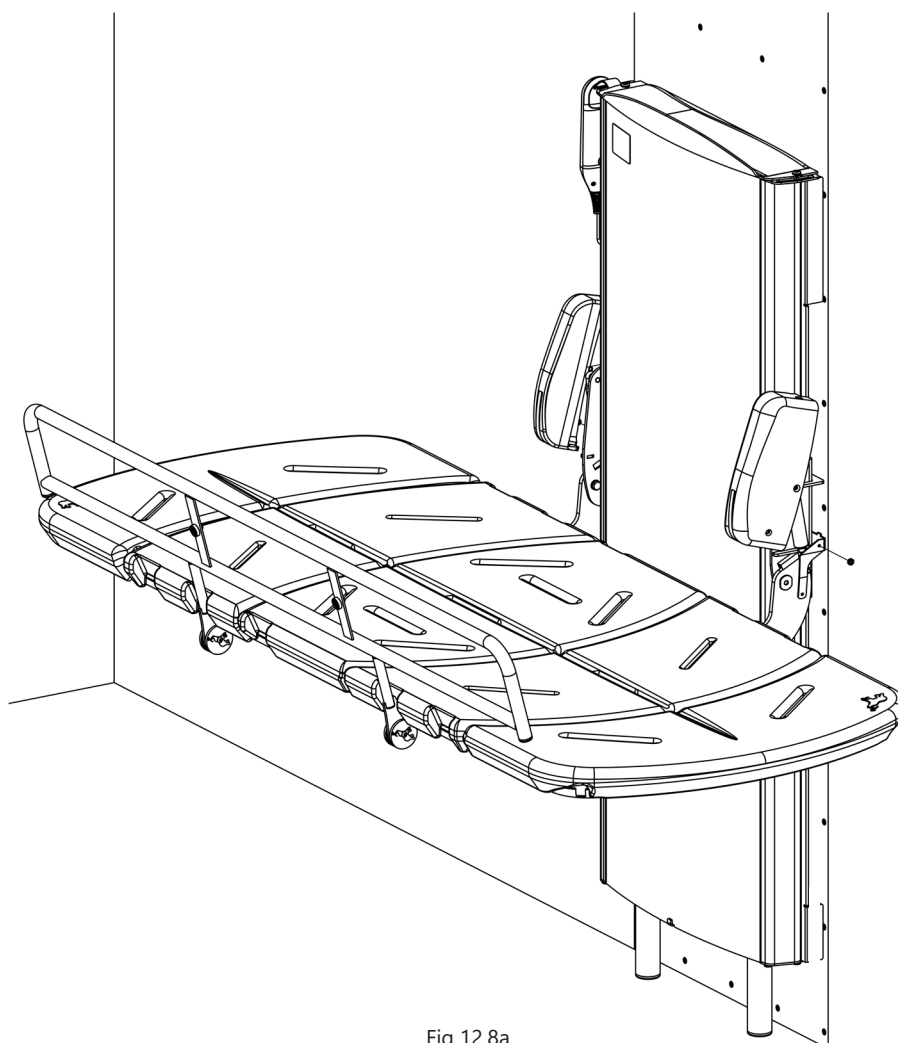

Fig 12.8a

- Align the four screw holes.
- Ensure the spacer for the middle horizontal screw is fitted between the internal bracket and cover as shown in Fig 12.8b. Please use the longer M5 x 12 mm screw for this fitting.
- Fit the remaining three M5 x 8mm screws as shown in Fig 12.8c.

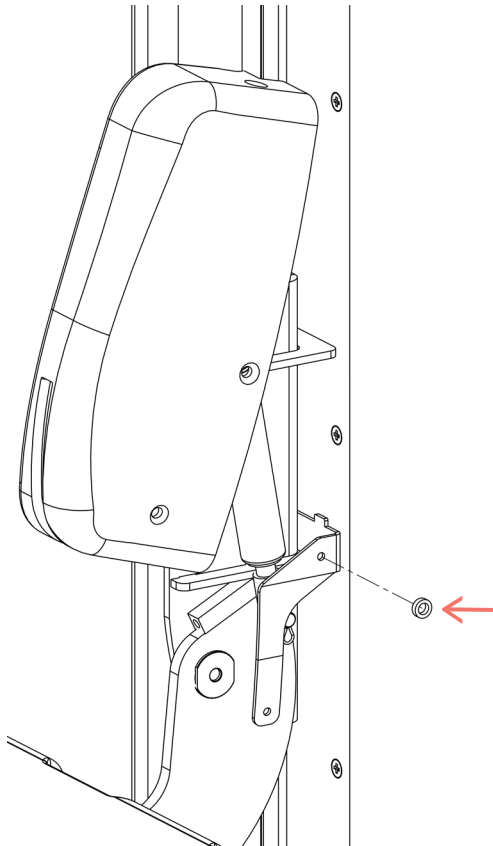

Fig 12.8b

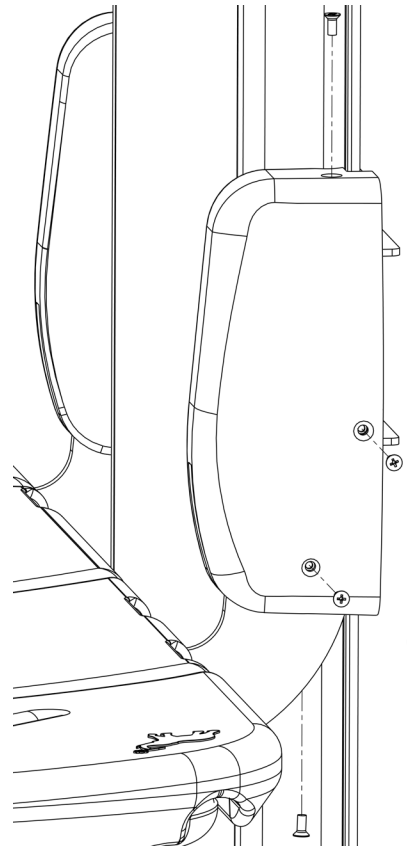

Fig 12.8c

12.8 Testing

Once complete, a full function test of the product is required, ensuring:

- The stretcher stows vertically and deploys correctly.
- The stretcher rises and falls with no obstructions through the full height range.
- Apply safe working load to stretcher and complete at least 3 cycles of the full height range checking for any excess noise or incorrect movement.
- The handset operates rise, fall and light on/off functions correctly.
- The guard(s) stow securely and is retained by the magnets.
- The guard(s) lock into position when deployed.

13 Moving & transporting the equipment

- It is anticipated that once installed, the equipment will not be transported. If you need to transport this equipment after unpacking it, please contact Astor Bannerman customer services team for advice (see contact details at the end of this booklet).

14 Product disposal

- The steel frame and ABS plastic front cover is widely recycled.
- Please check and dispose of in accordance with local regulations.
- The electronic components should be recycled in accordance with local WEEE regulations. For further advice, please contact Astor Bannerman:

email our support team: support@astorbannerman.co.uk
or call us on: +44 (0)1242 820820



15 Replaceable parts

The CTX2 is supplied for use with the following parts and accessories;

- SBU (main unit) 10.036.01.0003
- End pad - 10.036.70.0013
- Inner pad - 10.036.70.0021
- Centre pad - 10.036.70.0022

There are various parts of the product that may be replaced in the event of any failure or damage. In the event of any component failures or damage please contact us for advice;

email our support team: support@astorbannerman.co.uk
or call us on: +44 (0)1242 820820

16 Service record

Service engineer's name	Date of service	Actions undertaken	Signature

17 Training record

Trainee's name	Date of training	Type of training	Trainee's signature	Trainer's signature

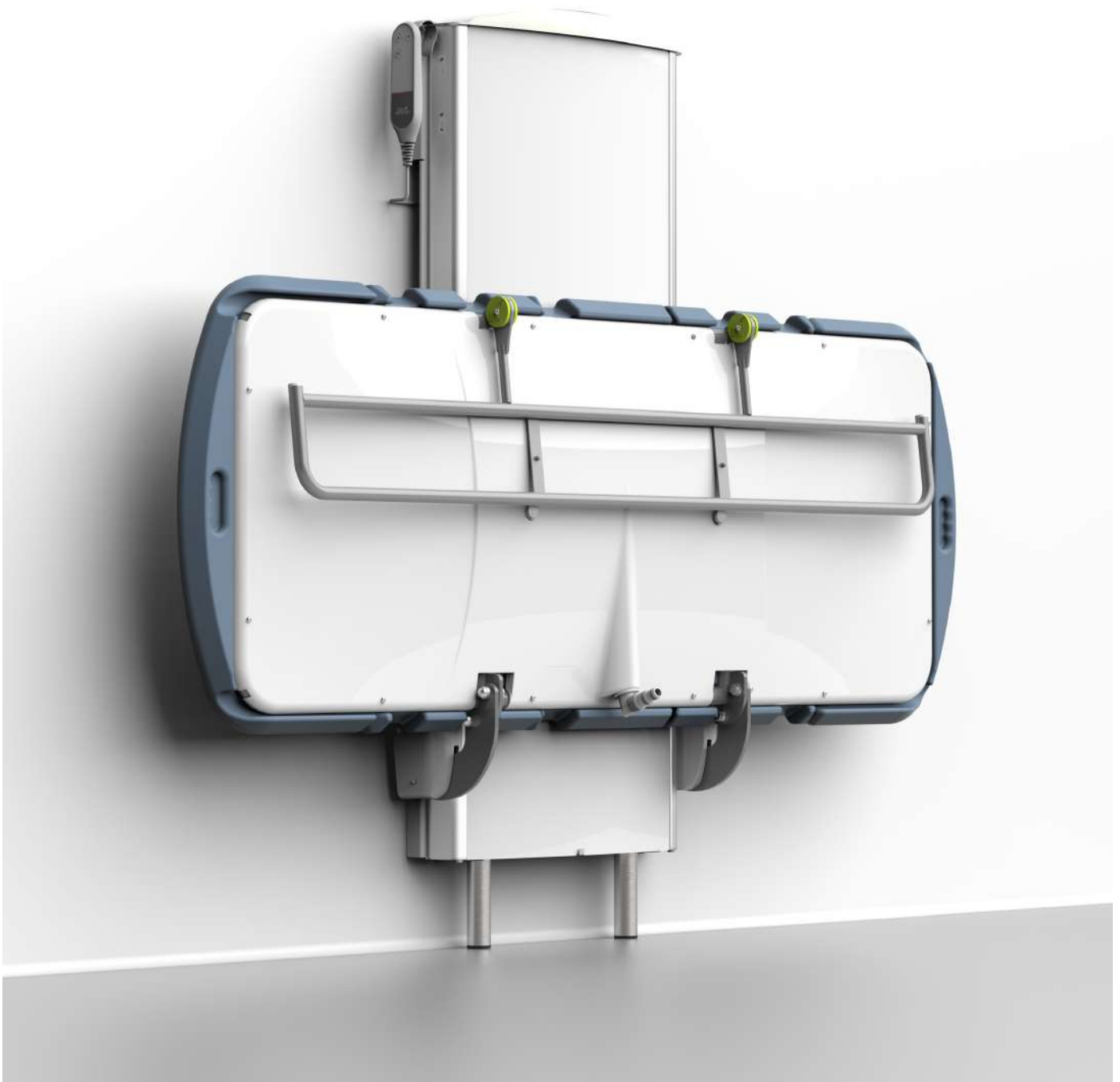

Specialist Bathing | Patient Handling | Changing & Showering

Astor Bannerman The Elephant Works, Andoversford Link, Cheltenham GL54 4LB

Phone: +44 (0) 1242 820820 | **Website:** www.astorbannerman.co.uk

Email: sales@astorbannerman.co.uk | support@astorbannerman.co.uk



astor 
bannerman
beyond routine