

CTM3 Owner Manual and Instructions for use.

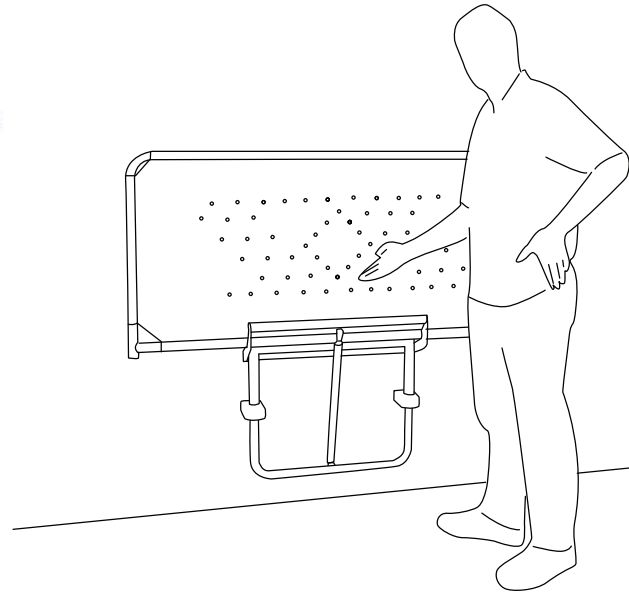

IMPORTANT
READ THIS
MANUAL
BEFORE USE



Guarantee / Warranty

This product is guaranteed against all defects in manufacture for a period of one year. This does not affect your statutory rights. Once registered, this product has a 3 year warranty against all defects in manufacture - see the terms and conditions below. This does not affect your statutory rights.

To validate your warranty and for full terms and conditions, please register your product and your details immediately on-line at <https://www.astorbannerman.co.uk/services/>, email our support team: support@astorbannerman.co.uk, or call us on 01242 820820. To maintain the warranty, the equipment must be serviced at least on an annual basis by a competent, factory trained technician. Service or repairs undertaken by persons other than competent qualified technicians will invalidate this Warranty. This warranty is provided by Astor Bannerman to the registered Customer. Equipment requiring commissioning must be commissioned for this warranty to be valid.

Operating instructions for optional guard if fitted

To engage the optional guard: Ensure that the stretcher is in the horizontal position. Rotate the guard from underneath the stretcher forward & upward until vertical. Push gently downwards on the stretcher until the guard engages with the locking mechanism. To test the correct engagement, the guard should be pulled toward you & resistance should be felt.

To disengage the guard: lift the guard vertically & rotate forward & downwards. The guard should stow beneath the stretcher when not in use.

Cleaning: Clean the stretcher after each use to maintain hygiene standards.

The stretcher and frame may be cleaned using most mild cleaning agents. Abrasive cleaners should be avoided in order to maintain the semi-gloss finish of the white high tension stretcher material and the polished effect of the frame. Chemical agents must not be used, i.e., drain cleaners, acetone, oven cleaners or acids. Attention should always be paid to instruction labels on the outside of cleaning agent containers.

NOTE: If the unit is to be installed in a swimming pool or other area with a harsh environment it MUST be cleaned daily with clean water. Failure to do so will lead to the finish of the machine degrading.

Caution

The use of oil based products may adversely affect the white stretcher material. Oils and other petro-chemical products should be used sparingly and any residue removed immediately.

CTM3 instructions for use.

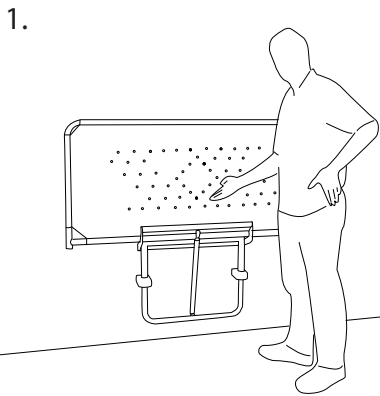

Approach stowed changing bed.

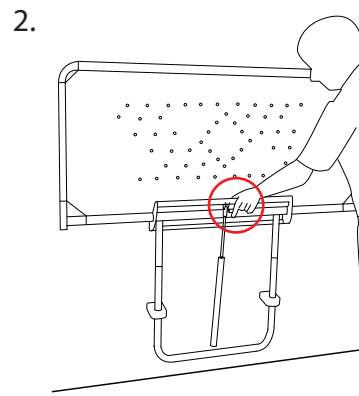

Grasp the handle and the trigger.

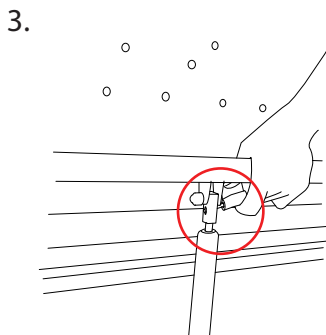

Squeeze trigger to adjust bed height.

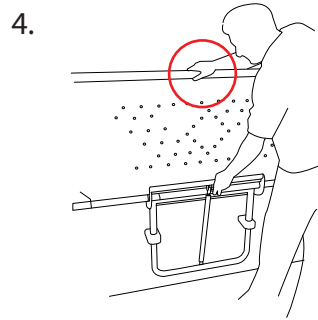

Slide the stretcher into position using the handle as a guide for the desired height.

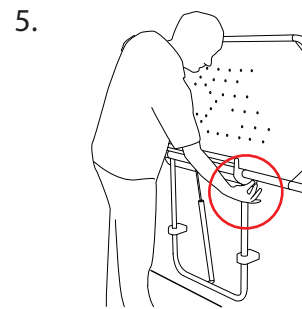

To unstow the bed pull the side mounted locking pin out.

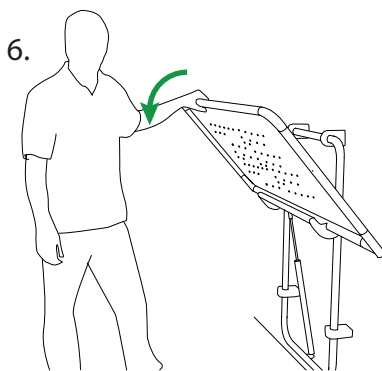

Unstow the bed.

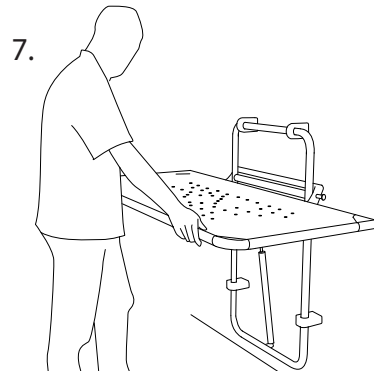

The bed is now ready for use.

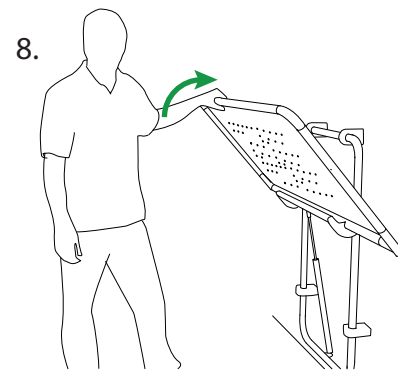

Once used, clean the bed and fold into the stowed position, the locking pin will engage automatically.