

# CTM3 Changing Table

## Pre Installation Check Sheet

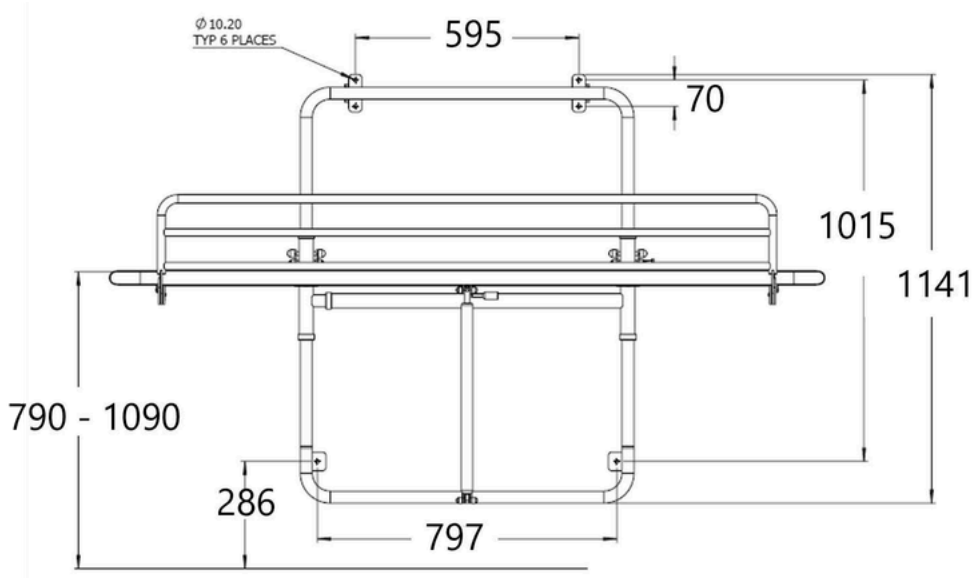

This sheet must be completed and returned before installation can take place  
Please read and check the sections below carefully before ticking each box



### Wall

1. The wall is load bearing and free of obstructions between 240 - 1500mm (11"-60") from the floor or
2. The wall is of stud-wall construction but strengthened to Astor-Bannerman's specification and no other, please call for details. Wall is free of obstructions 240 - 1500mm (11"-60") from the floor

### Access

1. The unit is not required to be installed through difficult access or
2. The unit is required to be installed upstairs/through difficult access but necessary arrangements have been made to assist the Astor Bannerman engineer

This last box must be ticked before we are able to release the goods for installation. We understand that if the above works are not complete, any on site waiting time will be charged to us at £80 per hour and should the site require a second visit due to the above requirements not being met an additional £499.00 per visit will be charged and we agree to pay those charges.

**Signed:** \_\_\_\_\_ **Date:** \_\_\_\_\_

**Print Name:** \_\_\_\_\_ **Job Number:** \_\_\_\_\_

**Site Address:** \_\_\_\_\_

